



PY32F030 Datasheet

32-bit ARM[®] Cortex[®]-M0+ Microcontroller



Puya Semiconductor (Shanghai) Co., Ltd.



Features

- Core
 - 32-bit ARM® Cortex® - M0+ CPU
 - Up to 48 MHz operating frequency
- Memories
 - Maximum 64 KB of Flash memory
 - Up to 8 KB SRAM
- Clock system
 - Internal 4/8/16/22.12/24 MHz RC Oscillator (HSI)
 - Internal 32.768 kHz RC oscillator (LSI)
 - 4 to 32 MHz crystal oscillator (HSE)
 - 32.768 kHz low speed crystal oscillator (LSE)
 - PLL (supports 2 octaves for HSI or HSE)
- Power management and reset
 - Operating voltage(x6 version): 1.7 to 5.5 V
 - Operating voltage(x7 version): 2.0 to 5.5 V
 - Low power modes: Sleep and Stop
 - Power-on/Power-down reset (POR/PDR)
 - Brownout Detect Reset (BOR)
 - Programmable Voltage Detection (PVD)
- General purpose input and output (I/O)
 - Up to 30 I/Os, all available as external interrupts
- 3-channel DMA controller
- 1 x 12-bit ADC
 - Supports up to 10 external input channels
 - Input voltage conversion range: 0 ~ V_{CC}
- Timers
 - 4 general purpose 16-bit timers (TIM3/TIM14/TIM16/TIM17)
 - A low-power timer (LPTIM), supports wake-up from stop mode
 - An Independent Watchdog Timer (IWDG)
 - A Window Watchdog Timer (WWDG)
 - A SysTick Timer
 - A IRTIM
- RTC
- Communication Interfaces
 - Two Serial Peripheral Interface (SPI)
 - Two Universal Synchronous / Asynchronous Transceivers (USARTs) with automatic baud-rate detection
 - An I²C interface , supports standard mode (100 kHz) , Fast mode (400 kHz) , supports 7-bit addressing mode
- Support 4-digit 8-segment common-cathode LED digital tube
 - Cyclic scanning of 1, 2, 3, 4 digits
- Hardware CRC-32 module
- Two comparators
- Unique UID
- Serial wire debug (SWD)
- Operating temp.(x6 version): -40 to 85 °C
- Operating temp.(x7 version): -40 to 105 °C
- Package:
 - LQFP32,QFN32(5*5),QFN32(4*4),QFN24,SSOP24,QFN20,TSSOP20,DFN8(1.5*1.5)

Contents

Features	2
1. Introduction.....	5
2. Functional Overview	17
2.1. Arm®Cortex®-M0+ core	17
2.2. Memories	17
2.3. Boot mode.....	17
2.4. Clock System	17
2.5. Power management.....	19
2.5.1. Power block diagram.....	19
2.5.2. Power monitoring.....	19
2.5.3. Voltage regulator	21
2.5.4. Low power mode	21
2.6. Reset.....	21
2.6.1. Power reset	21
2.6.2. System reset.....	21
2.7. General-purpose input and output (GPIOs).....	21
2.8. DMA	21
2.9. Interrupt.....	21
2.9.1. Interrupt controller NVIC.....	21
2.9.2. Extended interrupt/event controller (EXTI).....	22
2.10. Analog to digital converter (ADC)	22
2.11. Comparators (COMP)	22
2.12. Timer	23
2.12.1. Advanced timer.....	23
2.12.2. General-purpose timer	23
2.12.3. Low power timer (LPTIM).....	24
2.12.4. IWDG.....	24
2.12.5. WWDG	24
2.12.6. SysTick timer	24
2.13. Real time clock (RTC)	24
2.14. I ² C interface.....	24
2.15. Universal synchronous asynchronous receiver/ transmitter (USART).....	25
2.16. Serial peripheral interface (SPI)	26
2.17. SWD	26
3. Pin Configuration.....	27
3.1. Port A multiplexing function mapping	53
3.2. Port B multiplexing function mapping	54
3.3. Port F multiplexing function mapping.....	54
4. Memory Map.....	55

5. Electrical Characteristics	59
5.1. Test conditions	59
5.1.1. Min and Max	59
5.1.2. Typical value.....	59
5.2. Absolute maximum ratings.....	59
5.3. Operating conditions	60
5.3.1. General operating conditions	60
5.3.2. Operating conditions at power-up / power-down.....	60
5.3.3. Embedded reset and PVD module characteristics.....	60
5.3.4. Operating current characteristics	61
5.3.5. Wakeup time from low-power modes	62
5.3.6. External clock source characteristics	63
5.3.7. Internal high frequency clock source HSI characteristics	65
5.3.8. Internal low frequency clock source LSI characteristics	65
5.3.9. Phase-locked loop PLL characteristics	65
5.3.10. Memory characteristics	66
5.3.11. EFT characteristics.....	66
5.3.12. ESD & LU Characteristics	66
5.3.13. Port characteristics	66
5.3.14. NRST pin characteristics.....	67
5.3.15. ADC characteristics	67
5.3.16. Comparator characteristics	68
5.3.17. Temperature sensor characteristics.....	69
5.3.18. Built-in reference voltage characteristics	69
5.3.19. Timer characteristics	69
5.3.20. Communication port characteristics	70
6. Package Information	73
6.1. LQFP32.....	73
6.2. QFN32(5*5).....	74
6.3. QFN32(4*4).....	75
6.4. QFN24.....	76
6.5. SSOP24	77
6.6. QFN20.....	78
6.7. TSSOP20	79
6.8. DFN8(1.5*1.5).....	80
7. Ordering Information	81
8. Version History	82

1. Introduction

PY32F030 series microcontrollers are MCUs with high performance 32-bit ARM® Cortex® -M0 + core, wide voltage operating range. It has embedded up to 64 KB Flash and 8 KB SRAM memory, a maximum operating frequency of 48 MHz, and contains various products in different package types. The chip integrates multi-channel I²C, SPI, USART and other communication peripherals, one channel 12-bits ADC, five 16 bits timers, and two-channel comparators.

PY32F030 series microcontrollers are -40 ~ 85 °C and -40 ~ 105 °C, the operating voltage range is 1.7 ~ 5.5 V and 2.0 ~ 5.5 V. The chip provides sleep and stop low-power operating modes from meeting different low-power applications.

The PY32F030 series of microcontrollers are suitable for various application scenarios, such as controllers, portable devices, PC peripherals, gaming and GPS platforms, industrial applications.

Puya Confidential

Table 1-1 PY32F030x6 series LQFP32 product features and peripheral counts

Peripherals		PY32F030K18T6	PY32F030K14T6	PY32F030K28T6	PY32F030K28T6-E	PY32F030K26T6
Flash(KB)		64	16	64	64	32
SRAM(KB)		8	2	8	8	4
Timers	Advanced	1 (16-bit)				
	General pupose	4 (16-bit)				
	Low power	1				
	RTC	1				
	SysTick	2				
Comm. interfaces	SPI	2				
	I ² C	1				
	USART	2				
DMA		3 ch				
RTC		Yes				
GPIOs		28		30		
12-bit ADC (external + internal)		10+2				
Comparators		2				
Max. CPU frequency		48 MHz				
Operating Voltage		1.7~5.5 V				
Operating Temperature		-40 ~ 85 °C				
Package		LQFP32				

Table 1-2 PY32F030x6 series QFN32 product features and peripheral counts

Peripherals		PY32F030K28U6	PY32F030K28U6-E	PY32F030K38U6-E	PY32F030K48U6-E	PY32F030K46U6-E
Flash (KB)		64	64	64	64	32
SRAM (KB)		8	8	8	8	8
Timers	Advanced	1 (16-bit)				
	General pupose	4 (16-bit)				
	Low power	1				
	RTC	1				
	SysTick	2				
Comm. interfaces	SPI	2				
	I ² C	1				
	USART	2				
DMA		3 ch				
RTC		Yes				
GPIOs		30				
12-bit ADC(external + internal)		10+2				
Comparators		2				
Max. CPU frequency		48 MHz				
Operating Voltage		1.7~5.5 V				
Operating Temp.		-40 ~ 85 °C				
Package		QFN32(5*5)			QFN32(4*4)	

Table 1-3 PY32F030x6 series QFN24/SSOP24 product features and peripheral counts

Peripherals		PY32F030E18U6-E	PY32F030E16U6-E	PY32F030E18M6	PY32F030E26M6	PY32F030E26M6-E	
Flash (KB)		64	32	64	32	32	
SRAM (KB)		8	4	8	4	4	
Timers	Advanced	1 (16-bit)					
	General pupose	4 (16-bit)					
	Low power	1					
	RTC	1					
	SysTick	2					
Comm. interfaces	SPI	2					
	I ² C	1					
	USART	2					
DMA		3 ch					
RTC		Yes					
GPIOs		23	22				
12-bit ADC (external + internal)		10+2					
Comparators		2					
Max. CPU frequency		48 MHz					
Operating Voltage		1.7 ~ 5.5 V					
Operating Temperature		-40 ~ 85 °C					
Package		QFN24			SSOP24		

Table 1-4 PY32F030x6 series QFN20 product features and peripheral counts

Peripherals		PY32F030F18U6	PY32F030F18U6-E	PY32F030F16U6	PY32F030F28U6	PY32F030F28U6-E	PY32F030F26U6	PY32F030F36U6	
Flash (KB)		64	64	32	64	64	32	32	
SRAM (KB)		8	8	4	8	8	4	4	
Timers	Advanced	1 (16-bit)							
	General purpose	4 (16-bit)							
	Low power	1							
	RTC	1							
	SysTick	2							
Comm. interfaces	SPI	2							
	I ² C	1							
	USART	2							
DMA		3 ch							
RTC		Yes							
GPIOs		18			18			17	
12-bit ADC (external + internal)		5+2			8+2			5+2	
Comparators		2							
Max. CPU frequency		48 MHz							
Operating Voltage		1.7~5.5 V							
Operating Temperature		-40 ~ 85 °C							
Package		QFN20							

Table 1-5 PY32F030x6 series TSSOP20 product features and peripheral counts

Peripherals		PY32F030F18P6	PY32F030F17P6	PY32F030F28P6	PY32F030F27P6	PY32F030F26P6	PY32F030F38P6	PY32F030F46P6
Flash (KB)		64	48	64	48	32	64	32
SRAM (KB)		8	6	8	6	4	8	4
Timers	Advanced	1 (16-bit)						
	General pupose	4 (16-bit)						
	Low power	1						
	RTC	1						
	SysTick	2						
Comm. interfaces	SPI	2						
	I ² C	1						
	USART	2						
DMA		3 ch						
RTC		Yes						
GPIOs		18						
12-bit ADC (external + internal)		2+2	8+2			9+2	8+2	
Comparators		2						
Max. CPU frequency		48 MHz						
Operating Voltage		1.7~5.5 V						
Operating Temperature		-40 ~ 85 °C						
Package		TSSOP20						

Table 1-6 PY32F030x6 series DFN8 product features and peripheral counts

Peripheral		PY32F030L18D6-E	PY32F030L14D6
Flash (KB)		64	16
SRAM (KB)		8	2
Timers	Advanced	1 (16-bit)	
	General pupose	4 (16-bit)	
	Low power	1	
	SysTick	1	
	Watchdog	2	
Comm. interfaces	SPI	1	
	I ² C	1	
	USART	1	
DMA		3ch	
RTC		Yes	
GPIOs		7	
12-bit ADC (external + internal)		4+2	
Comparators		2	
Max. CPU frequency		48 MHz	
Operating Voltage		1.7~5.5 V	
Operating Temperature		-40 ~ 85 °C	
Package		DFN8(1.5*1.5)	

Table 1-7 PY32F030x7 series LQFP32 product features and peripheral counts

Peripheral		PY32F030K16T7	PY32F030K28T7
Flash (KB)		32	64
SRAM (KB)		4	8
Timers	Advanced	1 (16-bit)	
	General pupose	4 (16-bit)	
	Low power	1	
	SysTick	1	
	Watchdog	2	
Comm. interfaces	SPI	2	
	I ² C	1	
	USART	2	
DMA		3ch	
RTC		Yes	
GPIOs		28	30
12-bit ADC (external + internal)		10+2	
Comparators		2	
Max. CPU frequency		48 MHz	
Operating Voltage		2.0 ~ 5.5 V	
Operating Temp.		-40 ~ 105 °C	
Package		LQFP32	

Table 1-8 PY32F030x7 series QFN32 product features and peripheral counts

Peripheral		PY32F030K28U7	PY32F030K28U7-E	PY32F030K48U7-E
Flash (KB)		64	64	64
SRAM (KB)		8	8	8
Timers	Advanced	1 (16-bit)		
	General pupose	4 (16-bit)		
	Low power	1		
	SysTick	1		
	Watchdog	2		
Comm. interfaces	SPI	2		
	I ² C	1		
	USART	2		
DMA		3ch		
RTC		Yes		
GPIOs		30		
12-bit ADC (external + internal)		10+2		
Comparators		2		
Max. CPU frequency		48 MHz		
Operating Voltage		2.0 ~ 5.5 V		
Operating Temp.		-40 ~ 105 °C		
Package		QFN32 (5*5)		QFN32 (4*4)

Table 1-9 PY32F030x7 series QFN20 product features and peripheral counts

Peripheral		PY32F030F28U7	PY32F030F28U7-E
Flash (KB)		64	64
SRAM (KB)		8	8
Timers	Advanced	1 (16-bit)	
	General pupose	4 (16-bit)	
	Low power	1	
	SysTick	1	
	Watchdog	2	
Comm. interfaces	SPI	2	
	I ² C	1	
	USART	2	
DMA		3ch	
RTC		Yes	
GPIOs		18	
12-bit ADC (external + internal)		5+2	8+2
Comparators		2	
Max. CPU frequency		48 MHz	
Operating Voltage		2.0 ~ 5.5 V	
Operating Temp.		-40 ~ 105 °C	
Package		QFN20	

Table 1-10 PY32F030x7 series TSSOP20 product features and peripheral counts

Peripheral		PY32F030F28P7-E	PY32F030F27P7	PY32F030F26P7	PY32F030F38P7
Flash memory (KB)		64	48	32	64
SRAM (KB)		8	6	4	8
Timers	Advanced	1 (16-bit)			
	General pupose	4 (16-bit)			
	Low power	1			
	SysTick	1			
	Watchdog	2			
Comm. interfaces	SPI	2			
	I ² C	1			
	USART	2			
DMA		3ch			
RTC		Yes			
GPIOs		18			18
12-bit ADC (external + internal)		8+2			9+2
Comparators		2			
Max. CPU frequency		48 MHz			
Operating Voltage		2.0 ~ 5.5 V			
Operating Temp.		-40 ~ 105 °C			
Package		TSSOP20			

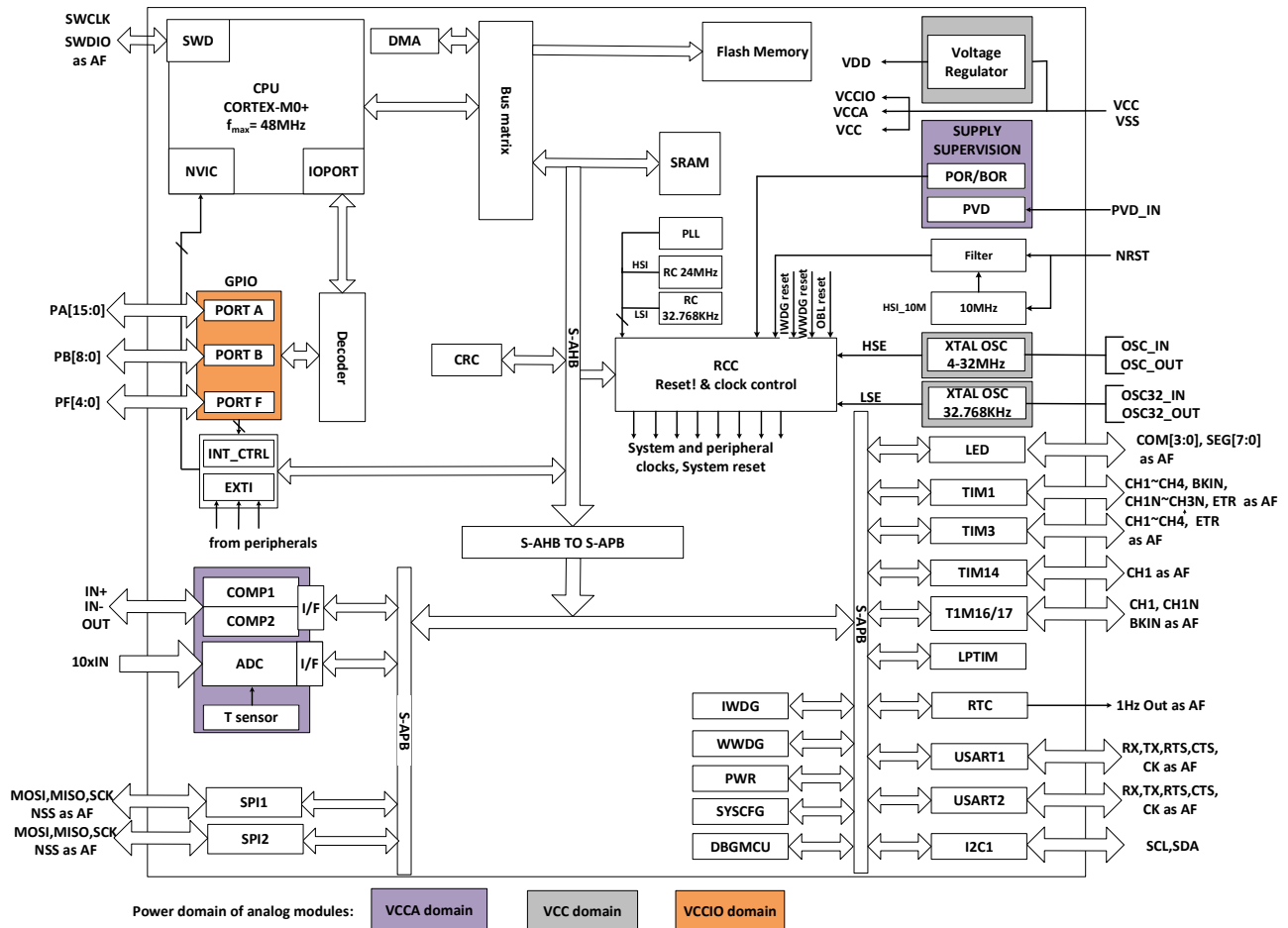

Figure 1-1 Functional Module

2. Functional Overview

2.1. Arm®Cortex®-M0+ core

The Arm® Cortex® - M0+ is an entry-level 32-bit Arm Cortex processor designed for a wide range of embedded applications. It provides developers with significant benefits, including:

- Simple structure, easy to learn and program
- Ultra-low power consumption, energy-saving operation
- Reduced code density and more

Cortex-M0+ processor is a 32-bit core optimized for area and power consumption and is a 2-stage pipeline Von Neumann architecture. The processor offers high-end processing hardware, including single-cycle multipliers, through a streamlined but powerful instruction set and an extensively optimized design. Moreover, it delivers the superior performance expected from a 32-bit architecture computer, with a higher coding density than other 8 and 16-bit microcontrollers.

The Cortex-M0+ is tightly coupled with a Nested Vectored Interrupt Controller (NVIC).

2.2. Memories

The on-chip integrated SRAM is accessed by bytes (8 bits), half-word (16 bits) or word (32 bits).

The on-chip integrated Flash consists of two different physical areas:

- Main flash area, which contains application and user data
- The information area has 4 KB, and it includes the following parts:
 - Option bytes
 - UID bytes
 - System memory

The protection of Flash main memory includes the following mechanisms:

- Read protection(RDP) prevents access from outside.
- Write protection (WRP) control prevents unwanted writes (confuse by program memory pointer from PC). The minimum protection unit for write protection is 4 KB.
- Option byte write protection, special unlocking design.

2.3. Boot mode

Through BOOT0 pin and boot configuration bit nBOOT1 (stored in Option bytes), three different boot modes can be selected, as shown in the following table:

Table 2-1 Boot configuration

Boot mode configuration		Mode
nBOOT1 bit	BOOT0 pin	
X	0	Select Main flash as the boot area
1	1	Select System memory as the boot area
0	1	Select SRAM as the boot area

The Boot loader program is stored in the System memory and used to download the Flash program through the USART interface.

2.4. Clock System

After the CPU starts, the default system clock frequency is HSI 8 MHz, and the system clock frequency and system clock source can be reconfigured after the program runs. The high frequency clocks that can be selected are:

- A 4 /8/16/ 22.12/ 24 MHz configurable internal high precision HSI clock.
- A 32.768 KHz configurable internal LSI clock.
- 4 ~ 32 MHz HSE clock can enable the CSS function to detect HSE. If CSS fails, the hardware will automatically convert the system clock to HSI, and software configures the HSI frequency. Simultaneously, CPU NMI interrupt is generated.
- A 32.768 KHz LSE clock.

- PLL clock, PLL source can be selected as HSI and HSE. If HSE source is selected, when CSS is enabled and CSS fails, PLL and HSE are turned off and hardware selects the system clock source as HSI.

The AHB clock can be divided based on the system clock, and the APB clock can be divided based on the AHB clock. AHB and APB clock frequencies up to 48 MHz.

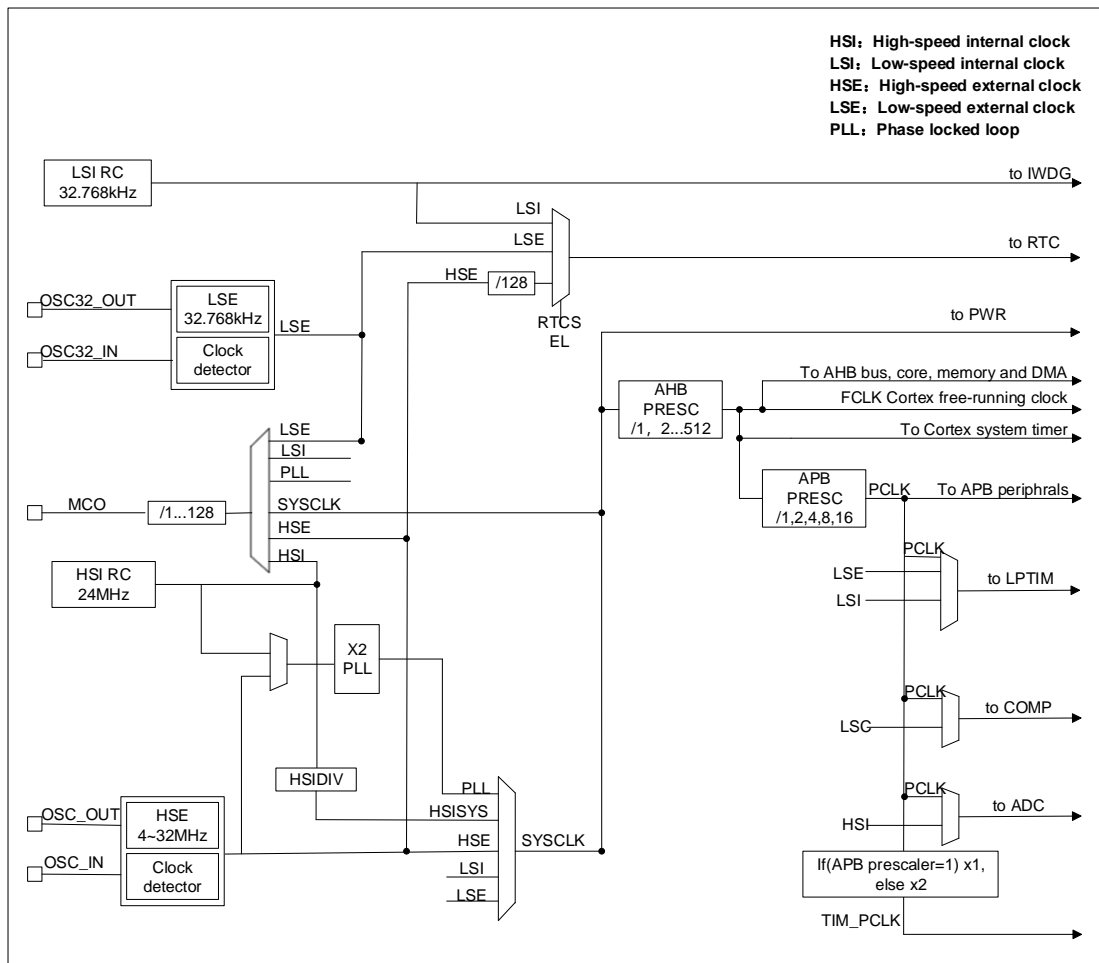

Figure 2-1 System Clock Structure Diagram

2.5. Power management

2.5.1. Power block diagram

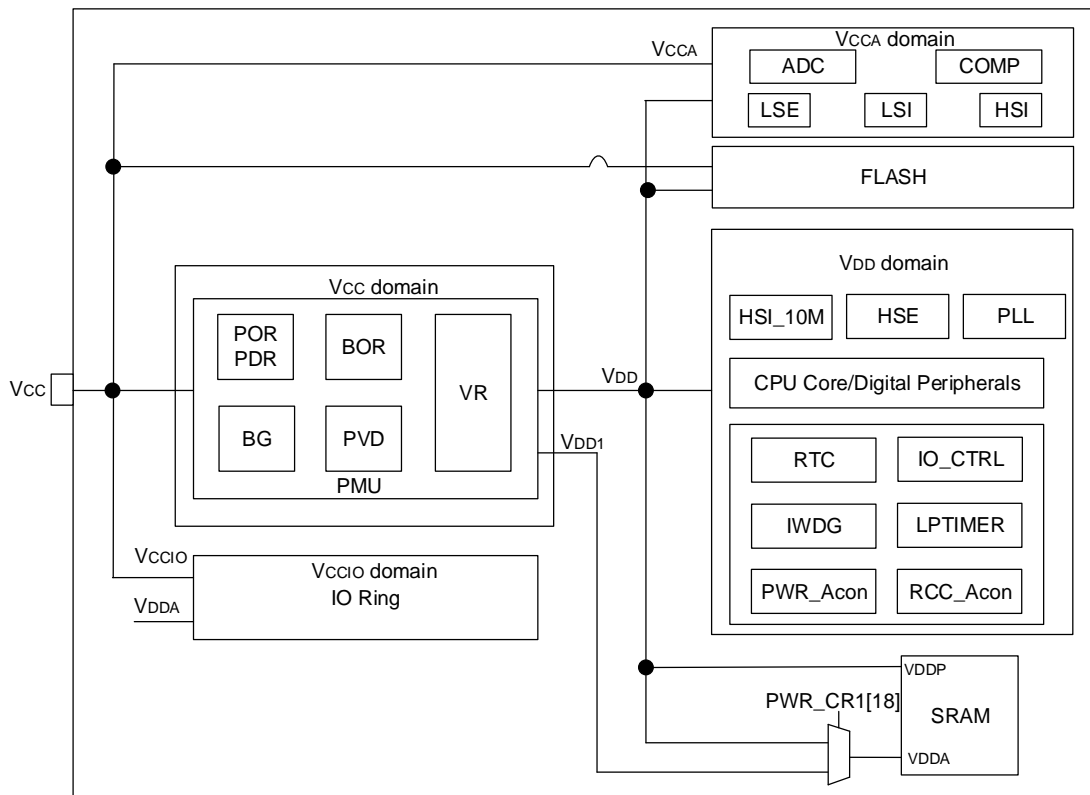

Figure 2-2 Power Block Diagram

Table 2-2 Power Block Diagram

No.	Power supply	Condition	Power value	Describe
1	V _{CC}	x6 version	1.7 V ~ 5.5 V	The chip is supplied with power through the power pins, and its power supply module is part of the analogue circuit.
		x7 version	2.0 V ~ 5.5 V	
2	V _{CCA}	x6 version	1.7 V ~ 5.5 V	Power to most analogue modules from V _{CC} PAD (a separate power supply PAD can also be designed).
		x7 version	2.0 V ~ 5.5 V	
3	V _{CCIO}	x6 version	1.7 V ~ 5.5 V	Power supply to IO, from V _{CC} PAD
		x7 version	2.0 V ~ 5.5 V	
4	V _{DD}	-	1.2 V/1.0 V ± 10 %	VR supplies power to the main logic circuits and SRAM inside the chip. When the MR is powered, it outputs 1.2V. According to the software configuration, entering the stop mode can be powered by MR or LPR, and the LPR output is determined to be 1.2V or 1.0V.

2.5.2. Power monitoring

2.5.2.1. Power on reset (POR/PDR)

The Power on reset (POR)/Power down reset (PDR) module is designed to provide power-on and power-off reset for the chip. The module keeps working in all modes.

2.5.2.2. Brown-out reset (BOR)

In addition to POR/ PDR, BOR (brown-out reset) is also implemented. BOR can only be enabled and disabled through the option byte.

When the BOR is turned on, the BOR threshold can be selected by the Option byte, and both the rising and falling detection points can be configured individually.

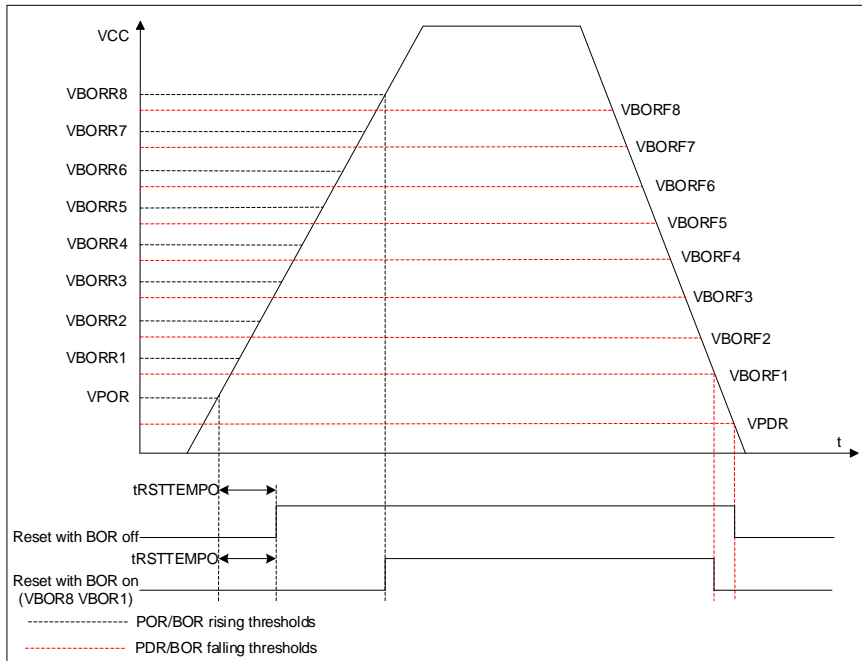

Figure 2-3 POR/PDR/BOR threshold

2.5.2.3. Voltage detection (PVD)

Programmable Voltage Detector (PVD) module can be used to detect the V_{CC} power supply (it can also detect the voltage of the PB7 pin), and the detection point can be configured through the register. When V_{CC} is higher or lower than the detection point of PVD, a corresponding reset flag is generated.

This event is internally connected to line 16 of EXTI , depending on the rising/falling edge configuration of EXTI line 16. When V_{CC} rises above the PVD detection point, or V_{CC} falls below the PVD detection point , an interrupt is generated. In the service program, users can perform urgent shutdown tasks.

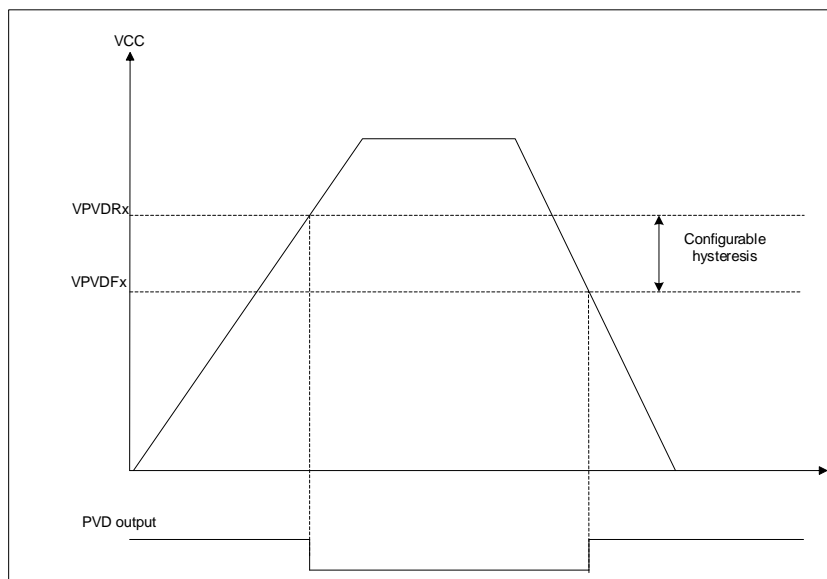

Figure 2-4 PVD Threshold

2.5.3. Voltage regulator

The chip designs two voltage regulators:

- MR (Main regulator) keeps working when the chip is in normal operating state.
- LPR (Low power regulator) provides a lower power consumption option in stop mode.

2.5.4. Low power mode

In addition to the normal operating mode, the chip has 2 low-power modes:

- **Sleep mode:** Peripherals can be configured to keep working when the CPU clock is off (NVIC, SysTick, etc.). It is recommended only to enable the modules that must work, and close the module after the module works.
- **Stop mode:** In this mode, the contents of SRAM and registers are maintained, High-speed clock PLL, HSI and HSE are turned off, and most modules of clocks in the V_{DD} domain are stopped. GPIO, PVD, COMP output, RTC and LPTIM can wake up stop mode.

2.6. Reset

Two resets are designed in the chip: power and system reset.

2.6.1. Power reset

A power reset occurs in the following situations:

- Power on/off reset (POR/PDR)
- Brown-out reset (BOR)

2.6.2. System reset

A system reset occurs when the following events occur:

- Reset of NRST pin
- Windowed Watchdog Reset (WWDG)
- Independent Watchdog Reset (IWDG)
- SYSRESETREQ software reset
- Option byte load reset (OBL)
- Power reset (POR/PDR , BOR)

2.7. General-purpose input and output (GPIOs)

The software configures each GPIO as output (push-pull or open-drain), input (floating, pull-up/down, analogue), peripheral multiplexing function, and locking mechanism freeze I/O port configuration function.

2.8. DMA

Direct Memory Access (DMA) provides high-speed data transfer between peripherals and memory or between memory and memory.

DMA controller has three channels, and each channel is responsible for managing memory access requests from one or more peripherals. The DMA controller includes an arbiter for handling DMA requests for each DMA request's priority..

DMA supports circular buffer management, eliminating the need for user code to intervene when the controller reaches the end of the buffer.

Each channel is directly connected to a dedicated hardware DMA request, and each channel also supports software triggering. These functions are configured through software.

DMA is available for peripherals: SPI, I²C, USART, all TIMx timers (except TIM14 and LPTIM) and ADC.

2.9. Interrupt

The PY32F030 handles exceptions through the Cortex-M0+ processor's embedded Vectored Interrupt Controller (NVIC) and an Extended Interrupt/Event Controller (EXTI).

2.9.1. Interrupt controller NVIC

NVIC is a tightly coupled IP inside the Cortex-M0+ processor. The NVIC can handle NMI (Non-Masable Interrupts) and maskable external interrupts from outside the processor and Cortex-M0+ internal exceptions. NVIC provides flexible priority management.

The tight coupling of the processor core to the NVIC greatly reduces the delay between an interrupt event and the initiation of the corresponding interrupt service routine (ISR). The ISR vectors are listed

in a vector table, stored at a base address of the NVIC. The vector table base address determines the vector address of the ISR to execute, and the ISR is used as the offset composed of serial numbers.

If a high-priority interrupt event occurs and a low-priority interrupt event is just waiting to be serviced, the later-arriving high-priority interrupt event will be serviced first. Another optimization is called tail-chaining. When returning from a high-priority ISR and then starting a pending low-priority ISR, unnecessary pushes and pops of processor contexts will be skipped. This reduces latency and improves power efficiency.

NVIC features:

- Low latency interrupt handling
- Level 4 Interrupt Priority
- Supports one NMI interrupt
- Supports 32 maskable external interrupts
- Supports 10 Cortex-M0+ exceptions
- High-priority interrupts can interrupt low-priority interrupt responses
- Support tail-chaining optimization
- Hardware Interrupt Vector Retrieval

2.9.2. Extended interrupt/event controller (EXTI)

EXTI adds flexibility to handle physical wire events and generates wake-up events when the processor wakes up from stop mode.

The EXTI controller has multiple channels, including a maximum of 16 GPIOs, 1 PVD output, 2 COMP outputs, RTC and LPTIM wake-up signals. GPIO, PVD and COMP can be configured to be triggered by a rising edge, falling edge or double edge. Any GPIO signal can be configured as EXTI0 ~ 15 channel through the select signal.

- Each EXTI line can be independently masked through registers.
- The EXTI controller can capture pulses shorter than the internal clock period.
- Registers in the EXTI controller latch each event. Even in stop mode, after the processor wakes up from stop mode, it can identify the wake-up source or identify the GPIO and event that caused the interrupt.

2.10. Analog to digital converter (ADC)

The chip has a 12-bit SAR-ADC. The module has up to 12 channels to be measured, including 10 external channels and 2 internal channels.

- The conversion mode of each channel can be set to single, continuous, sweep, discontinuous mode. Conversion results are stored in left or right-aligned 16-bit data registers.
- An analogue watchdog allows the application to detect if the input voltage exceeds a user-defined high or low threshold.
- The ADC has been implemented to operate at a low frequency, resulting in lower power consumption.
- At the end of sampling, conversion, and continuous conversion, an interrupt request is generated when the conversion voltage exceeds the threshold when simulating the watchdog.

2.11. Comparators (COMP)

- Each comparator has configurable positive or negative inputs for flexible voltage selection
 - Multiple I/O pins
 - Power supply V_{CC}
 - The output of the temperature sensor
 - Internal reference voltage and 3-part values supplied by divider (1/4, 1/2, 3/4)
- The hysteresis function is configurable
- Programmable speed and power consumption
- The output can be connected to the input of I/O or timer as a trigger
 - OCREF_CLR event (current control of cycle by cycle)
 - Brakes for fast PWM shutdown

Each COMP has interrupt generation capability to act as a wake-up of the chip from low-power modes (sleep and stop modes) (via EXTI)

2.12. Timer

The characteristics of different timers of PY32F030 are shown in the following table:

Table 2-3 Timer Features

Types	Timer	Bit Width	Counting Direction	Prescaler	DMA	Capture /compare channel	Complementary output
Advanced	TIM1	16-bit	Superior, Down, Center aligned	1 ~ 65536	Support	4	3
General purpose	TIM3	16-bit	Superior, Down, Center aligned	1 ~ 65536	Support	4	-
	TIM14	16-bit	Superior	1 ~ 65536	-	1	-
	TIM16, TIM17	16-bit	Superior	1 ~ 65536	Support	1	1

2.12.1. Advanced timer

The advanced timer (TIM1) consists of a 16-bit auto-reload counter driven by a programmable prescaler. It can be used in various scenarios, including pulse length measurement of input signals (input capture) or generating output waveforms (output compare, output PWM, complementary PWM with dead-time insertion).

TIM1 includes 4 independent channels:

- Input capture
- Output comparison
- PWM generation (edge or center-aligned mode)
- Single pulse mode output

If TIM1 is configured as a standard 16-bit timer, it has the same characteristics as the TIMx timer. Full modulation capability (0-100%) if configured as a 16-bit PWM generator.

In the MCU debug mode, TIM1 can freeze counting.

The timer feature with the same architecture is shared so that the TIM1 can work with other timers for synchronization or event chaining through the timer chaining function.

TIM1 supports the DMA function.

2.12.2. General-purpose timer

2.12.2.1. TIM3

- The general-purpose timer TIM3 consists of a 16-bit auto-reload counter driven by a 16-bit programmable prescaler. It has 4 independent channels, each for input capture/output compare, PWM or single pulse mode output.
- TIM3 can work with TIM1 through the timer link function.
- TIM3 supports the DMA function.
- The TIM3 can process quadrature (incremental) encoder signals and digital outputs from 1 to 3 Hall Effect Sensors.
- In the MCU debug mode, the TIM 3 can freeze counting.

2.12.2.2. TIM14

- The general-purpose timer TIM14 consists of a 16-bit auto-reload counter driven by a 16-bit programmable prescaler.
- TIM14 has one independent channel for input capture/output compare, PWM or single pulse mode output.
- In the MCU debug mode, the TIM14 can freeze counting.

2.12.2.3. TIM16/TIM17

- The general-purpose timer TIM16 and TIM17 consists of a 16-bit auto-reload counter driven by programmable prescaler.
- TIM16/TIM17 have 1 independent channel for input capture/output compare, PWM or single pulse mode output.
- TIM16/TIM17 have complementary outputs with dead time.
- TIM16/TIM17 supports the DMA function.
- In the MCU debug mode, TIM 16/TIM17 can freeze counting.

2.12.3. Low power timer (LPTIM)

- LPTIM is a 16-bit up counter with a 3-bit prescaler and only support a single count.
- LPTIM can be configured as a stop mode wakeup source.
- In the MCU debug mode, LPTIM can freeze the count value.

2.12.4. IWDG

- Independent watchdog (IWDG) is integrated in the chip, and this module has the characteristics of high-security level, accurate timing and flexible use. IWDG finds and resolves functional confusion due to software failure and triggers a system reset when the counter reaches the specified timeout value.
- The IWDG is clocked by LSI, so even if the main clock fails, it can keep working.
- IWDG is the best suited for applications that require the watchdog as a standalone process outside of the main application and do not have high timing accuracy constraints.
- Controlling of option byte can enable IWDG hardware mode.
- IWDG is the wake-up source of stop mode, which wakes up stop mode by reset.
- In the MCU debug mode, IWDG can freeze the count value.

2.12.5. WWDG

The system window watchdog is based on a 7-bit down counter and can be set to free-run. It acts as a watchdog to reset the system when a failure shows. The count clock is the APB clock (PCLK). It has early warning interrupt capability, and the counter can be freeze in the MCU debug mode.

2.12.6. SysTick timer

SysTick counters are specifically for real-time operating systems (RTOS) also can use as standard down counters.

SysTick Features:

- 24-bit count down
- Self-loading capability
- An interrupt can be generated when the counter reaches 0 (maskable)

2.13. Real time clock (RTC)

- The real-time clock is an independent timer. It has a set of continuous counting counters, which can provide a clock calendar function under the corresponding software configuration. Modifying the value of the counter can reset the current time and date of the system.
- RTC is a 32-bit programmable counter with a prescale factor of up to 2^{20} bits.
- The RTC counter clock source can be LSI and the stop wake-up source.
- RTC can generate alarm interrupt, second interrupt and overflow interrupt (maskable).
- RTC supports clock calibration.
- In the MCU debug mode, RTC can freeze counting.

2.14. I²C interface

I²C (inter-integrated circuit) bus interface connects the microcontroller and the serial I²C bus. It provides multi-master capability and controls all I²C bus specific sequences, protocols, arbitration and timing. Standard (Sm) and fast (Fm) are supported.

I²C Features:

- Slave and Master mode
- Multi-host function: can be Master or Slave
- Support different communication speeds
 - Standard Mode (Sm): Up to 100 kHz
 - Fast Mode (Fm): up to 400 kHz
- As Master
 - Generate Clock
 - Generation of Start and Stop
- As Slave
 - Programmable I²C address detection
 - Discovery of the Stop bit
- 7-bit addressing mode
- General call
- Status flag
 - Transmit/receive mode flags
 - Byte transfer complete flag
 - I²C busy flag bit
- Error flag
 - Master arbitration loss
 - ACK failure after address/data transfer
 - Start/Stop error
 - Overrun/Underrun (clock stretching function disable)
- Optional Clock Stretching
- Single-byte buffer with DMA capability
- Software reset
- Analogue noise filter function

2.15. Universal synchronous asynchronous receiver/ transmitter (USART)

PY32F030 contains 2 USARTs with precisely the same functions.

The Universal Synchronous Asynchronous Transceiver (USART) provides a flexible method for full-duplex data exchange with external devices using the industry-standard NRZ asynchronous serial data format. The USART utilizes a fractional baudrate generator to provide a wide range of baudrate options. It supports simultaneous one-way communication and half-duplex single-wire communication, and it also allows multi-processor communication.

Automatic baudrate detection is supported.

High-speed data communication can be achieved by using the DMA method of the multi-buffer configuration.

USART features:

- Full-duplex asynchronous communication
- NRZ standard format
- Configurable 16 times or 8 times oversampling for increased flexibility in speed and clock tolerance
- Programmable baudrate shared by transmit and receive, up to 4.5 Mbit/s
- Automatic baudrate detection
- Programmable data length of 8 or 9 bits
- Configurable stop bits (1 bit or 2 bits)
- Synchronous mode and clock output function for synchronous communication
- Single-wire half-duplex communication
- Independent transmit and receive enable bits
- Hardware flow control
- Receive/transmit bytes by DMA buffer
- Detection flag
 - Receive full buffer
 - Send empty buffer
 - End of transmission
- Parity Control
 - Send check digit

- Check the received data
- Flagged interrupt sources
 - CTS change
 - Send empty register
 - Send completed
 - Receive full data register
 - Bus idle detected
 - Overflow error
 - Frame error
 - Noise operation
 - Error detection
- Multiprocessor communication
 - If the address does not match, enter silent mode
- Wake-up from silent mode: by idle detection and address flag detection

2.16. Serial peripheral interface (SPI)

PY32F030 contains two SPIs.

Serial Peripheral Interface (SPI) allows the chip to communicate with external devices in half-duplex, full-duplex, and simplex synchronous serial communication. This interface can be configured in Master mode and provides the communication clock (SCK) for external slave devices. The interface can also work in a multi-master configuration.

The SPI features are as follows:

- Master or Slave mode
- 3-wire full-duplex simultaneous transmission
- 2-wire half-duplex synchronous transmission (with bidirectional data line)
- 2-wire simplex synchronous transmission (no bidirectional data line)
- 8-bit or 16-bit transmission frame selection
- Support multi-master mode
- 8 Master mode baudrate prescaler factors (max $f_{PCLK}/4$)
- Slave mode frequency (max $f_{PCLK}/4$)
- Both Master and Slave modes can be managed by software or hardware NSS: dynamic change of Master/Slave operating mode
- Programmable clock polarity and phase
- Programmable data order, MSB first or LSB first
- Dedicated transmit and receive flags that can trigger interrupts
- SPI bus busy status flag
- Motorola mode
- Interrupt-causing Master mode faults, overloads
- Two 32-bit Rx and Tx FIFOs with DMA capability

2.17. SWD

The ARM SWD interface allows serial debugging tools to be connected to the PY32F030.

3. Pin Configuration

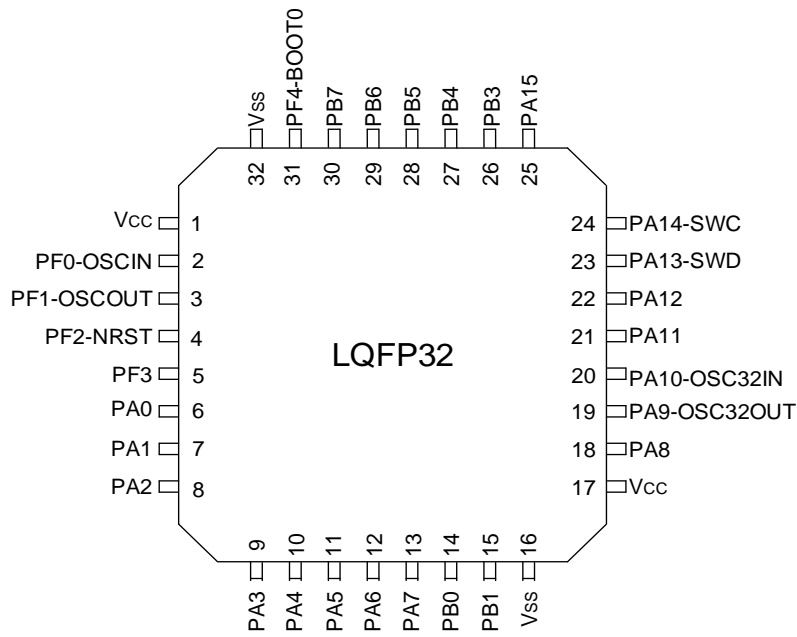

Figure 3-1 LQFP32 Pinout1 PY32F030K1xTx (Top view)

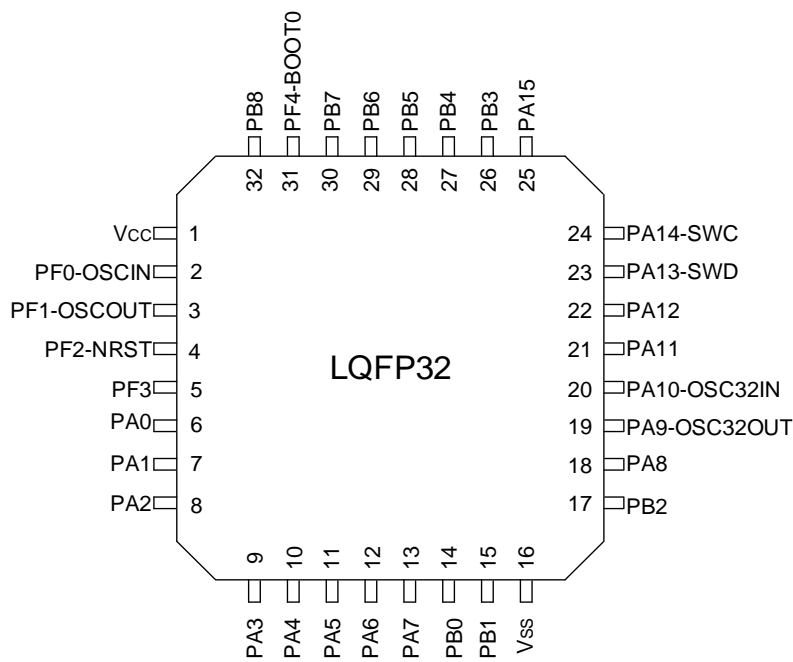

Figure 3-2 LQFP32 Pinout2 PY32F030K2xTx / PY32F030K2xTx-E (Top view)

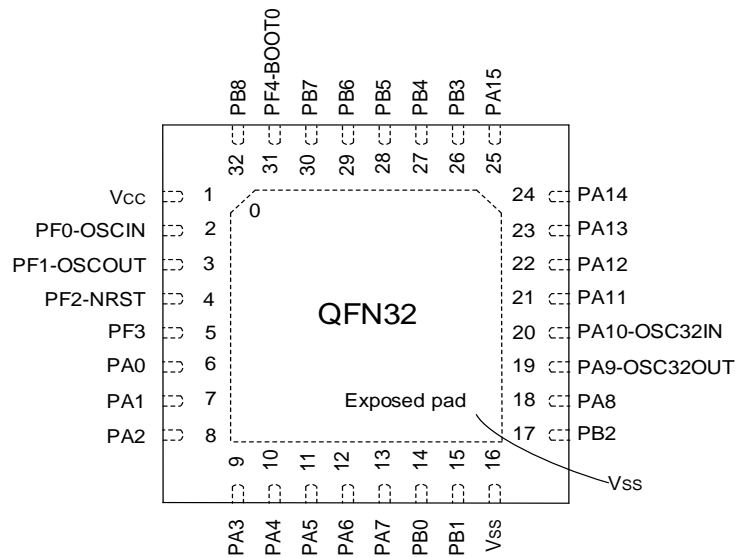

Figure 3-3 QFN32(5*5) Pinout2 PY32F030K2xUx / PY32F030K2xUx-E (Top view)

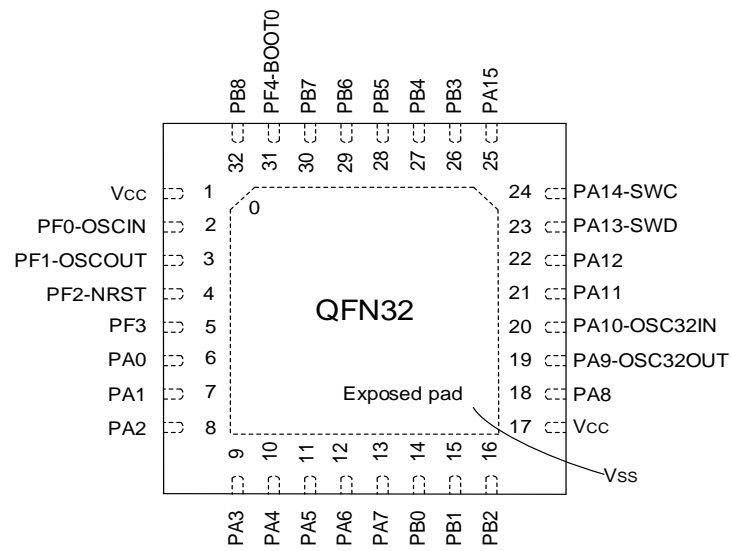

Figure 3-4 QFN32(5*5) Pinout3 PY32F030K3xUx-E (Top view)

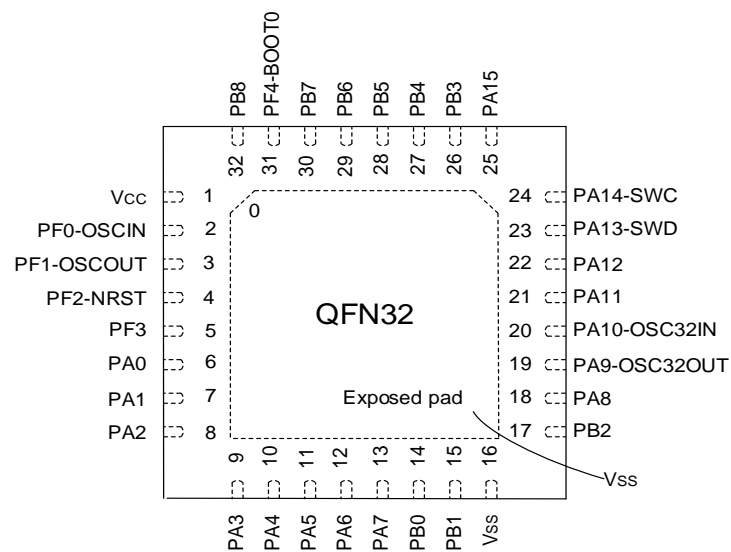

Figure 3-5 QFN32(4*4) Pinout4 PY32F030K4xUx-E (Top view)

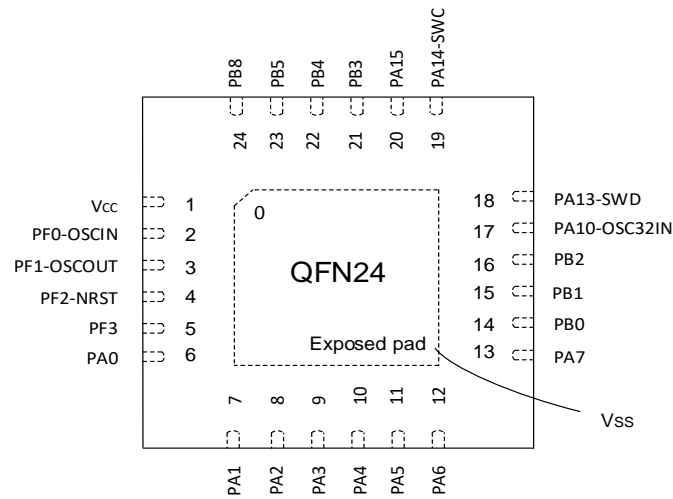

Figure 3-6 QFN24 Pinout1 PY32F030E1xUx-E (Top view)

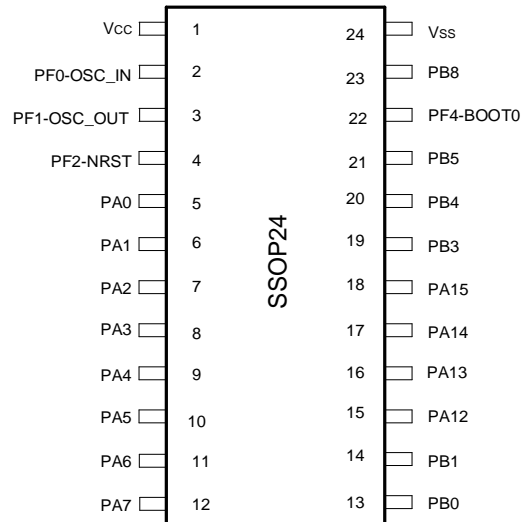

Figure 3-7 SSOP24 Pinout1 PY32F030E1xMx (Top view)

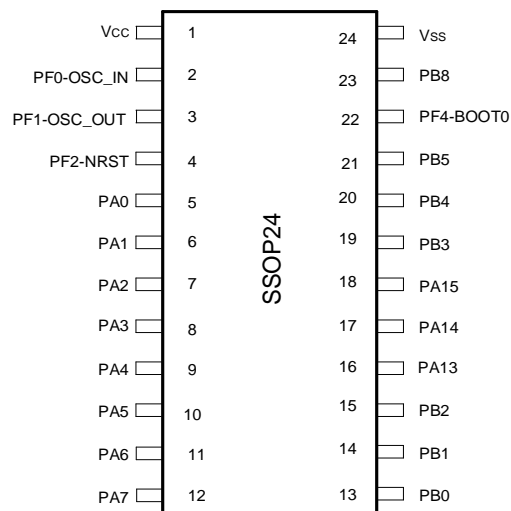

Figure 3-8 SSOP24 Pinout2 PY32F030E2xMx / PY32F030E2xMx-E (Top view)

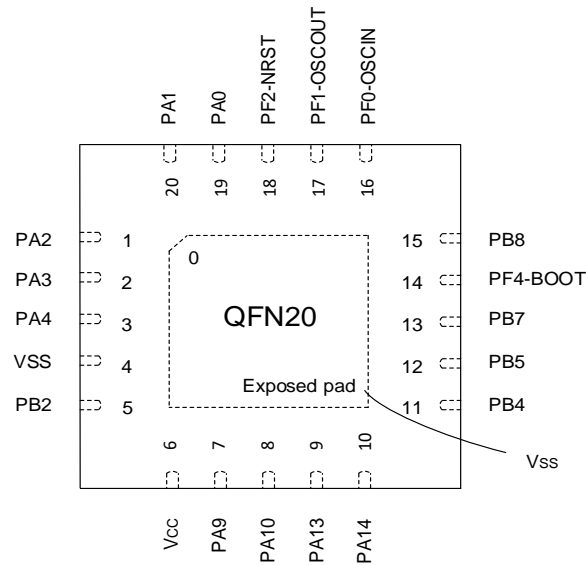

Figure 3-9 QFN20 Pinout1 PY32F030F1xUx / PY32F030F1xUx-E (Top view)

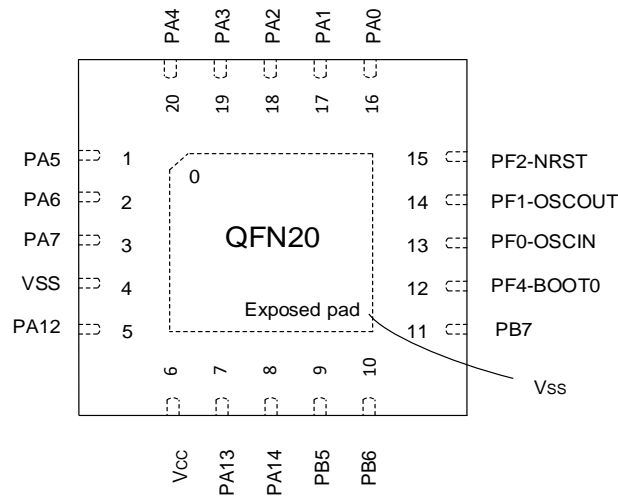

Figure 3-10 QFN20 Pinout2 PY32F030F2xUx / PY32F030F2xUx-E (Top view)

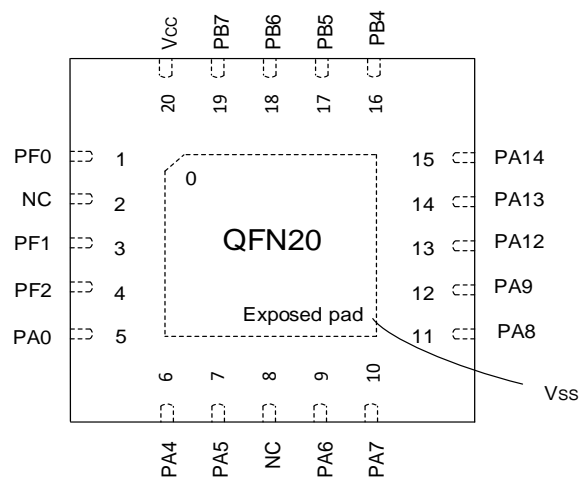

Figure 3-11 QFN20 Pinout3 PY32F030F3xUx (Top view)

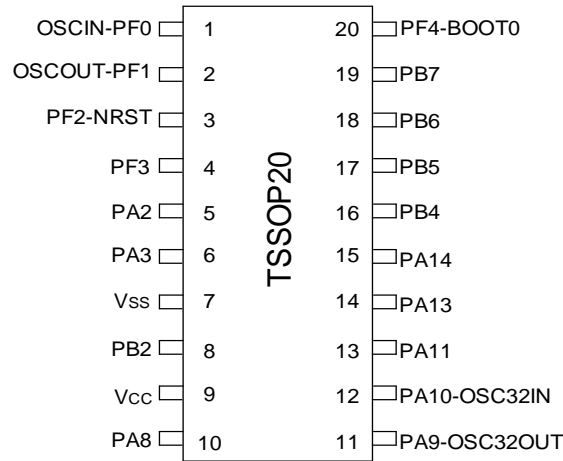

Figure 3-12 TSSOP20 Pinout1 PY32F030F1xPx (Top view)

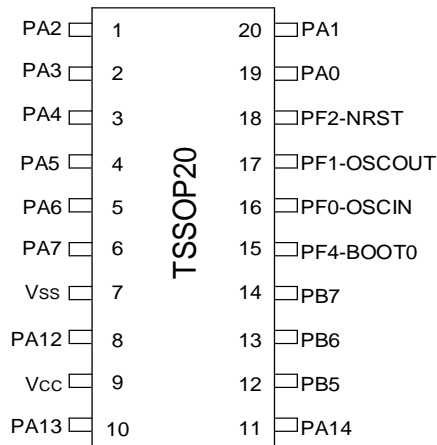

Figure 3-13 TSSOP20 Pinout2 PY32F030F2xPx / PY32F030F2xPx-E (Top view)

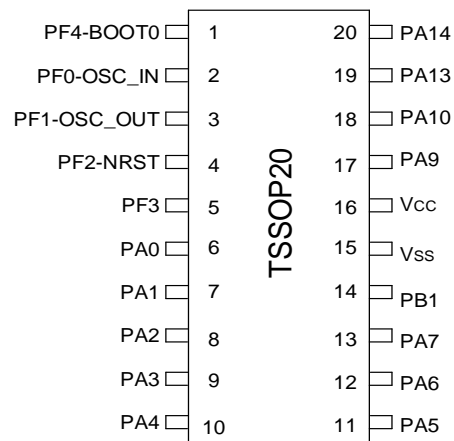

Figure 3-14 TSSOP20 Pinout3 PY32F030F3xPx (Top view)

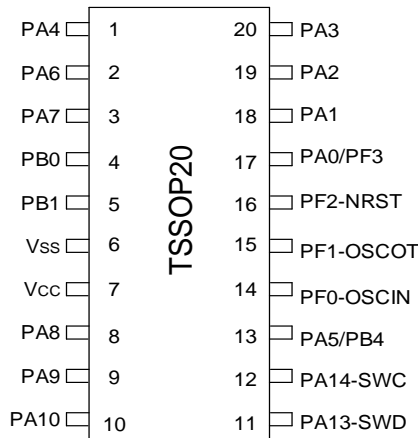

Figure 3-15 TSSOP20 Pinout4 PY32F030F4xP (Top view)

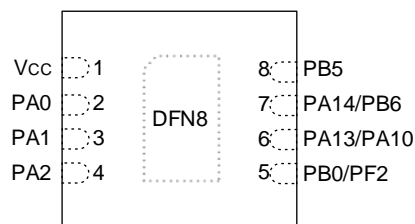

Figure 3-16 DFN8(1.5*1.5) Pinout1 PY32F030L1xDx / PY32F030L1xDx-E (Top view)

Table 3-1 Pin definition terminology and symbols

Types		Symbol	Definition
Port type		S	Supply pin
		G	Ground p in
		I/O	Input/output pin
		NC	Undefined
Port structure		COM	5 V port, support analogue input and output function
		RST	Reset port, with internal weak pull-up resistor, does not support analog input and output function
		_L	LED COM port with analog input and output functions
Notes		-	Unless other specified, all ports are used as floating inputs between and after reset
Port function	Multiplexing function	-	Function selected by GPIOx_AFR register
	Additional features	-	Directly selected or enabled through peripheral registers

Table 3-2 LQFP32/QFN32 pin definitions

Packages					Reset	Port type	Port structure	Functions	
LQFP32 K1	LQFP32 K2	QFN32(5*5) K2	QFN32(5*5) K3	QFN32(4*4) K4				Multiplexing	Additional
-	-	-	-	-	NC	NC			
1	1	1	1	1	V _{CC}	S		Digital power supply	
2	2	2	2	2	PF0-OSC_IN- (PF0)	I/O	COM	SPI2_SCK USART2_RX TIM14_CH1 USART1_RX USART2_TX I ² C_SDA	OSC_IN
3	3	3	3	3	PF1-OSC_OUT- (PF1)	I/O	COM	SPI2_MISO USART2_TX USART1_TX USART2_RX I ² C_SCL SP1_NSS TIM14_CH1	OSC_OUT
4	4	4	4	4	PF2-NRST ⁽¹⁾	I/O	RST	MCO SPI2_MOSI USART2_RX	NRST
5	5	5	5	5	PF3	I/O	COM	USART1_TX USART2_TX SPI2_MISO SPI1_NSS TIM3_CH3 RTC_OUT	COMP2_INP
6	6	6	6	6	PA0	I/O	COM	SPI2_SCK USART1_CTS LED_DATA_B USART2_CTS COMP1_OUT TIM1_CH3 TIM1_CH1N SPI1_MISO USART2_TX IR_OUT	ADC_IN0 COMP1_INM
7	7	7	7	7	PA1	I/O	COM	SPI1_SCK USART1_RTS USART2_RTS LED_DATA_C	COMP1_INP ADC_IN1

Packages					Reset	Port type	Port structure	Functions	
LQFP32 K1	LQFP32 K2	QFN32(5*5) K2	QFN32(5*5) K3	QFN32(4*4) K4				Multiplexing	Additional
								EVENTOUT	
								SPI1_MOSI	
								USART2_RX	
								TIM1_CH4	
								TIM1_CH2N	
								MCO	
8	8	8	8	8	PA2	I/O	COM	SPI1_MOSI	COMP2_INM ADC_IN2
								USART1_TX	
								USART2_TX	
								LED_DATA_D	
								COMP2_OUT	
								SPI1_SCK	
								TIM3_CH1	
								I ² C_SDA	
9	9	9	9	9	PA3	I/O	COM	SPI2_MISO	COMP2_INP ADC_IN3
								USART1_RX	
								USART2_RX	
								LED_DATA_E	
								EVENTOUT	
								SPI1_MOSI	
								TIM1_CH1	
								I ² C_SCL	
10	10	10	10	10	PA4	I/O	COM	SPI1_NSS	ADC_IN4
								USART1_CK	
								SPI2_MOSI	
								LED_DATA_F	
								TIM14_CH1	
								USART2_CK	
								ENENTOUT	
								RTC_OUT	
								TIM3_CH3	
								USART2_TX	
11	11	11	11	11	PA5	I/O	COM	SPI1_SCK	ADC_IN5
								LED_DATA_G	
								LPTIM_ETR	
								EVENTOUT	
								TIM3_CH2	
								USART2_RX	
								MCO	
12	12	12	12	12	PA6	I/O	COM	SPI1_MISO	ADC_IN6

Packages					Reset	Port type	Port structure	Functions	
LQFP32 K1	LQFP32 K2	QFN32(5*5) K2	QFN32(5*5) K3	QFN32(4*4) K4				Multiplexing	Additional
								TIM3_CH1	
								TIM1_BKIN	
								LED_DATA_DP	
								TIM16_CH1	
								COMP1_OUT	
								USART1_CK	
								RTC_OUT	
13	13	13	13	13	PA7	I/O	COM	SPI1_MOSI	ADC_IN7
								TIM3_CH2	
								TIM1_CH1N	
								TIM14_CH1	
								TIM17_CH1	
								EVENTOUT	
								COMP2_OUT	
								USART1_TX	
								USART2_TX	
								I ² C_SDA	
								SPI1_MISO	
14	14	14	14	14	PB0	I/O	COM	SPI1_NSS	ADC_IN8
								TIM3_CH3	
								TIM1_CH2N	
								EVENTOUT	
								COMP1_OUT	
15	15	15	15	15	PB1	I/O	COM	TIM14_CH1	COMP1_INM ADC_IN9
								TIM3_CH4	
								TIM1_CH3N	
								EVENTOUT	
16	16	16	-	16	V _{SS}	S		Ground	
-	17	17	16	17	PB2	I/O	COM	USART1_RX	COMP1_INP
								USART2_RX	
								SPI2_SCK	
17	-	-	17	-	V _{CC}	S		Digital power supply	
18	18	18	18	18	PA8	I/O	COM	SPI2_NSS	-
								USART1_CK	
								TIM1_CH1	
								USART2_CK	
								MCO	
								EVENTOUT	
								USART1_RX	
								USART2_RX	

Packages					Reset	Port type	Port structure	Functions	
LQFP32 K1	LQFP32 K2	QFN32(5*5) K2	QFN32(5*5) K3	QFN32(4*4) K4				Multiplexing	Additional
								SPI1_MOSI	
								I ² C_SCL	
19	19	19	19	19	PA9	I/O	COM	SPI2_MISO	OSC32OUT
								USART1_TX	
								TIM1_CH2	
								MCO	
								I ² C_SCL	
								EVENTOUT	
								I ² C_SDA	
								TIM1_BK	
								SPI1_SCK	
								USART1_RX	
20	20	20	20	20	PA10	I/O	COM	SPI2_MOSI	OS32IN
								USART1_RX	
								TIM1_CH3	
								TIM17_BKIN	
								USART2_RX	
								I ² C_SDA	
								EVENTOUT	
								I ² C_SCL	
								SPI1_NSS	
								USART1_TX	
								IR_OUT	
21	21	21	21	21	PA11	I/O	COM	SPI1_MISO	-
								USART1_CTS	
								TIM1_CH4	
								EVENTOUT	
								USART2_CTS	
								I ² C_SCL	
								COMP1_OUT	
22	22	22	22	22	PA12	I/O	COM	SPI1_MOSI	-
								USART1_RTS	
								TIM1_ETR	
								USART2_RTS	
								EVENTOUT	
								I ² C_SDA	
								COMP2_OUT	
23	23	23	23	23	PA13(SWDIO) ⁽²⁾	I/O	COM	SWDIO	-
								IR_OUT	
								EVENTOUT	

Packages					Reset	Port type	Port structure	Functions	
LQFP32 K1	LQFP32 K2	QFN32(5*5) K2	QFN32(5*5) K3	QFN32(4*4) K4				Multiplexing	Additional
								SPI1_MISO	
								TIM1_CH2	
								USART1_RX	
								MCO	
24	24	24	24	24	PA14(SWCLK) ⁽²⁾	I/O	COM	SWCLK	
								USART1_TX	
								USART2_TX	-
								EVENTOUT	
								MCO	
25	25	25	25	25	PA15	I/O	COM_L	SPI1_NSS	
								USART1_RX	
								USART2_RX	-
								LED_COM0	
								EVENTOUT	
26	26	26	26	26	PB3	I/O	COM_L	SPI1_SCK	
								TIM1_CH2	
								USART1_RTS	COMP2_INM
								USART2_RTS	
								LED_COM1	
								EVENTOUT	
27	27	27	27	27	PB4	I/O	COM_L	SPI1_MISO	
								TIM3_CH1	
								USART2_CTS	
								USART1_CTS	COMP2_INP
								TIM17_BKIN	
								LED_COM2	
								EVENTOUT	
28	28	28	28	28	PB5	I/O	COM_L	SPI1_MOSI	
								TIM3_CH2	
								TIM16_BKIN	
								USART2_CK	
								USART1_CK	-
								LPTIM_IN1	
								LED_COM3	
								COMP1_OUT	
29	29	29	29	29	PB6	I/O	COM	USART1_TX	
								TIM1_CH3	
								TIM16_CH1N	COMP2_INP
								USART2_TX	
								SPI2_MISO	

Packages					Reset	Port type	Port structure	Functions	
LQFP32 K1	LQFP32 K2	QFN32(5*5) K2	QFN32(5*5) K3	QFN32(4*4) K4				Multiplexing	Additional
								I ² C_SCL	
								LPTIM_ETR	
								EVENTOUT	
30	30	30	30	30	PB7	I/O	COM	USART1_RX	COMP2_INM PVD_IN
								SPI2_MOSI	
								TIM17_CH1N	
								USART2_RX	
								I ² C_SDA	
								EVENTOUT	
31	31	31	31	31	PF4-BOOT0 ⁽³⁾	I/O	COM	-	BOOT0
-	32	32	32	32	PB8	I/O	COM	SPI2_SCK	COMP1_INP
								TIM16_CH1	
								I ² C1_SCL	
								USART2_TX	
								EVENTOUT	
								LED_DATA_A	
								USART1_TX	
								SPI2_NSS	
								I ² C_SDA	
								TIM17_CH1	
								IR_OUT	
32	-	-	-	-	V _{SS}	S		Ground	

1. Selecting PF2 or NRST is configured through option bytes .
2. After reset, the two pins of PA13 and PA14 are configured as SWDIO and SWCLK AF function, the former internal pull-up resistor, the latter internal pull-down resistor is activated.
3. PF4 -BOOT0 is the default digital input mode, and the pull-down is enabled.

Table 3-3 SSOP24/QFN24 pin definitions

Packages			Reset	Port type	Port structure	Functions	
SSOP24 E1	SSOP24 E2	QFN24 E1				Multiplexing	Additional
1	1	1	V _{CC}	S		Digital power supply	
2	2	2	PF0-OSC_IN- (PF0)	I/O	COM	SPI2_SCK	OSC_IN
						USART2_RX	
						TIM14_CH1	
						USART1_RX	
						USART2_TX	
I ² C_SDA							
3	3	3	PF1-OSC_OUT- (PF1)	I/O	COM	SPI2_MISO	OSC_OUT
						USART2_TX	
						USART1_TX	
						USART2_RX	
						I ² C_SCL	
						SP1_NSS	
TIM14_CH							
4	4	4	PF2-NRST ⁽¹⁾	I/O	RST	MCO	NRST
						SPI2_MOSI	
						USART2_RX	
-	-	5	PF3	I/O	COM	USART1_TX	COMP2_INP
						USART2_TX	
						SPI2_MISO	
						SPI1_NSS	
						TIM3_CH3	
RTC_OUT							
5	5	6	PA0	I/O	COM	SPI2_SCK	ADC_IN0 COMP1_INM
						USART1_CTS	
						LED_DATA_B	
						USART2_CTS	
						COMP1_OUT	
						TIM1_CH3	
						TIM1_CH1N	
						SPI1_MISO	
						USART2_TX	
IR_OUT							
6	6	7	PA1	I/O	COM	SPI1_SCK	COMP1_INP ADC_IN1
						USART1_RTS	
						USART2_RTS	
						LED_DATA_C	
						EVENTOUT	
						SPI1_MOSI	
						USART2_RX	
						TIM1_CH4	
						TIM1_CH2N	
MCO							

Packages			Reset	Port type	Port structure	Functions	
SSOP24 E1	SSOP24 E2	QFN24 E1				Multiplexing	Additional
7	7	8	PA2	I/O	COM	SPI1_MOSI USART1_TX USART2_TX LED_DATA_D COMP2_OUT SPI1_SCK TIM3_CH1 I ² C_SDA	COMP2_INM ADC_IN2
8	8	9	PA3	I/O	COM	SPI2_MISO USART1_RX USART2_RX LED_DATA_E EVENTOUT SPI1_MOSI TIM1_CH1 I ² C_SCL	COMP2_INP ADC_IN3
9	9	10	PA4	I/O	COM	SPI1_NSS USART1_CK SPI2_MOSI LED_DATA_F TIM14_CH1 USART2_CK ENENTOUT RTC_OUT TIM3_CH3 USART2_TX	ADC_IN4
10	10	11	PA5	I/O	COM	SPI1_SCK LED_DATA_G LPTIM_ETR EVENTOUT TIM3_CH2 USART2_RX MCO	ADC_IN5
11	11	12	PA6	I/O	COM	SPI1_MISO TIM3_CH1 TIM1_BKIN LED_DATA_DP TIM16_CH1 COMP1_OUT USART1_CK RTC_OUT	ADC_IN6
12	12	13	PA7	I/O	COM	SPI1_MOSI TIM3_CH2 TIM1_CH1N	ADC_IN7

Packages			Reset	Port type	Port structure	Functions	
SSOP24 E1	SSOP24 E2	QFN24 E1				Multiplexing	Additional
						TIM14_CH1	
						TIM17_CH1	
						EVENTOUT	
						COMP2_OUT	
						USART1_TX	
						USART2_TX	
						I ² C_SDA	
						SPI1_MISO	
13	13	14	PB0	I/O	COM	SPI1_NSS	ADC_IN8
						TIM3_CH3	
						TIM1_CH2N	
						EVENTOUT	
						COMP1_OUT	
14	14	15	PB1	I/O	COM	TIM14_CH1	COMP1_INM ADC_IN9
						TIM3_CH4	
						TIM1_CH3N	
						EVENTOUT	
-	15	16	PB2	I/O	COM	USART1_RX	COMP1_INP
						USART2_RX	
						SPI2_SCK	
-	-	17	PA10	I/O	COM	SPI2_MOSI	OS32IN
						USART1_RX	
						TIM1_CH3	
						TIM17_BKIN	
						USART2_RX	
						I ² C_SDA	
						EVENTOUT	
						I ² C_SCL	
						SPI1_NSS	
						USART1_TX	
						IR_OUT	
15	-	-	PA12	I/O	COM	SPI1_MOSI	-
						USART1_RTS	
						TIM1_ETR	
						USART2_RTS	
						EVENTOUT	
						I ² C_SDA	
						COMP2_OUT	
16	16	18	PA13(SWDIO) ⁽²⁾	I/O	COM	SWDIO	-
						IR_OUT	
						EVENTOUT	
						SPI1_MISO	
						TIM1_CH2	
						USART1_RX	

Packages			Reset	Port type	Port structure	Functions	
SSOP24 E1	SSOP24 E2	QFN24 E1				Multiplexing	Additional
						MCO	
17	17	19	PA14(SWCLK) ⁽²⁾	I/O	COM	SWCLK USART1_TX USART2_TX EVENTOUT MCO	-
18	18	20	PA15	I/O	COM_L	SPI1_NSS USART1_RX USART2_RX LED_COM0 EVENTOUT	-
19	19	21	PB3	I/O	COM_L	SPI1_SCK TIM1_CH2 USART1_RTS USART2_RTS LED_COM1 EVENTOUT	COMP2_INM
20	20	22	PB4	I/O	COM_L	SPI1_MISO TIM3_CH1 USART2_CTS USART1_CTS TIM17_BKIN LED_COM2 EVENTOUT	COMP2_INP
21	21	23	PB5	I/O	COM_L	SPI1_MOSI TIM3_CH2 TIM16_BKIN USART2_CK USART1_CK LPTIM_IN1 LED_COM3 COMP1_OUT	-
22	22	-	PF4-BOOT0 ⁽³⁾	I/O	COM	-	BOOT0
23	23	24	PB8	I/O	COM	SPI2_SCK TIM16_CH1 I ² C1_SCL USART2_TX EVENTOUT LED_DATA_A USART1_TX SPI2_NSS I ² C_SDA TIM17_CH1 IR_OUT	COMP1_INP

Packages			Reset	Port type	Port structure	Functions	
SSOP24 E1	SSOP24 E2	QFN24 E1				Multiplexing	Additional
24	24	-	V _{SS}	S		Ground	

1. Selecting PF2 or NRST is configured through option bytes .
2. After reset, the two pins of PA13 and PA14 are configured as SWDIO and SWCLK AF function, the former internal pull-up resistor, the latter internal pull-down resistor is activated.
3. PF4 -BOOT0 is the default digital input mode, and the pull-down is enabled.

Table 3-4 QFN20/TSSOP20 pin definitions

Packages							Reset	Port type	Port structure	Functions	
QFN20 F1	QFN20 F2	QFN20 F3	TSSOP20 F1	TSSOP20 F2	TSSOP20 F3	TSSOP20 F4				Multiplexing	Additional
16	13	1	1	16	2	14	PF0- OSC_IN- (PF0)	I/O	COM	SPI2_SCK USART2_RX TIM14_CH1 USART1_RX USART2_TX I ² C_SDA	OSC_IN
-	-	2	-	-	-	-	NC	NC			
17	14	3	2	17	3	15	PF1- OSC_OUT- (PF1)	I/O	COM	SPI2_MISO USART2_TX USART1_TX USART2_RX I ² C_SCL SP1_NSS TIM14_CH	OSC_OUT
18	15	4	3	18	4	16	PF2-NRST ⁽¹⁾	I/O	RST	MCO SPI2_MOSI USART2_RX	NRST
-	-	-	4	-	5	17	PF3	I/O	COM	USART1_TX USART2_TX SPI2_MISO SPI1_NSS TIM3_CH3 RTC_OUT	COMP2_INP
19	16	5	-	19	6	17	PA0	I/O	COM	SPI2_SCK USART1_CTS USART2_CTS COMP1_OUT TIM1_CH3 TIM1_CH1N SPI1_MISO USART2_TX IR_OUT	ADC_IN0 COMP1_INM
20	17	-	-	20	7	18	PA1	I/O	COM	SPI1_SCK	ADC_IN1

Packages							Reset	Port type	Port structure	Functions	
QFN20 F1	QFN20 F2	QFN20 F3	TSSOP20 F1	TSSOP20 F2	TSSOP20 F3	TSSOP20 F4				Multiplexing	Additional
										USART1_RTS	COMP1_INP
										USART2_RTS	
										EVENTOUT	
										SPI1_MOSI	
										USART2_RX	
										TIM1_CH4	
										TIM1_CH2N	
										MCO	
1	18	-	5	1	8	19	PA2	I/O	COM	SPI1_MOSI	ADC_IN2 COMP2_INM
										USART1_TX	
										USART2_TX	
										COMP2_OUT	
										SPI1_SCK	
										TIM3_CH1	
										I ² C_SDA	
2	19	-	6	2	9	20	PA3	I/O	COM	SPI2_MISO	ADC_IN3 COMP2_INP
										USART1_RX	
										USART2_RX	
										EVENTOUT	
										SPI1_MOSI	
										TIM1_CH1	
										I ² C_SCL	
3	20	6	-	3	10	1	PA4	I/O	COM	SPI1_NSS	ADC_IN4
										USART1_CK	
										SPI2_MOSI	
										TIM14_CH1	
										USART2_CK	
										EVENTOUT	
										RTC_OUT	
										TIM3_CH3	
										USART2_TX	
-	1	7	-	4	11	13	PA5	I/O	COM	SPI1_SCK	ADC_IN5
										LPTIM_ETR	

Packages							Reset	Port type	Port structure	Functions	
QFN20 F1	QFN20 F2	QFN20 F3	TSSOP20 F1	TSSOP20 F2	TSSOP20 F3	TSSOP20 F4				Multiplexing	Additional
										EVENTOUT	
										TIM3_CH2	
										USART2_RX	
										MCO	
-	-	8	-	-	-	-	NC	NC			
										SPI1_MISO	
										TIM3_CH1	
										TIM1_BKIN	
-	2	9	-	5	12	2	PA6	I/O	COM	TIM16_CH1	ADC_IN6
										COMP1_OUT	
										USART1_CK	
										RTC_OUT	
										SPI1_MOSI	
										TIM3_CH2	
										TIM1_CH1N	
										TIM14_CH1	
										TIM17_CH1	
-	3	10	-	6	13	3	PA7	I/O	COM	EVENTOUT	ADC_IN7
										COMP2_OUT	
										USART1_TX	
										USART2_TX	
										I ² C_SDA	
										SPI1_MISO	
										SPI1_NSS	
										TIM3_CH3	
-	-	-	-	-	-	4	PB0	I/O	COM	TIM1_CH2N	ADC_IN8
										EVENTOUT	
										COMP1_OUT	
										TIM14_CH1	
										TIM3_CH4	
-	-	-	-	-	14	5	PB1	I/O	COM	TIM1_CH3N	ADC_IN9 COMP1_INM
										EVENTOUT	
4	4	-	7	7	15	6	V _{SS}	S		Ground	

Packages							Reset	Port type	Port structure	Functions	
QFN20 F1	QFN20 F2	QFN20 F3	TSSOP20 F1	TSSOP20 F2	TSSOP20 F3	TSSOP20 F4				Multiplexing	Additional
5	-	-	8	-	-	-	PB2	I/O	COM	USART1_RX USART2_RX SPI2_SCK	COMP1_INP
6	6	20	9	9	16	7	V _{CC}	S		Digital power supply	
-	-	11	10	-	-	8	PA8	I/O	COM	SPI2_NSS USART1_CK TIM1_CH1 USART2_CK MCO EVENTOUT USART1_RX USART2_RX SPI1_MOSI I ² C_SCL	-
7	-	12	11	-	17	9	PA9	I/O	COM	SPI2_MISO USART1_TX TIM1_CH2 MCO I ² C_SCL EVENTOUT I ² C_SDA TIM1_BK SPI1_SCK USART1_RX	OSC32OUT
8	-	-	12	-	18	10	PA10	I/O	COM	SPI2_MOSI USART1_RX TIM1_CH3 TIM17_BKIN USART2_RX I ² C_SDA EVENTOUT I ² C_SCL SPI1_NSS	OS32IN

Packages							Reset	Port type	Port structure	Functions	
QFN20 F1	QFN20 F2	QFN20 F3	TSSOP20 F1	TSSOP20 F2	TSSOP20 F3	TSSOP20 F4				Multiplexing	Additional
										USART1_TX	
										IR_OUT	
-	-	-	13	-	-	-	PA11	I/O	COM	SPI1_MISO	-
										USART1_CTS	
										TIM1_CH4	
										EVENTOUT	
										USART2_CTS	
										I ² C_SCL	
										COMP1_OUT	
-	5	13	-	8	-	-	PA12	I/O	COM	SPI1_MOSI	-
										USART1_RTS	
										TIM1_ETR	
										USART2_RTS	
										EVENTOUT	
										I ² C_SDA	
										COMP2_OUT	
9	7	14	14	10	19	11	PA13 (SWDIO) ⁽²⁾	I/O	COM	SWDIO	-
										IR_OUT	
										EVENTOUT	
										SPI1_MISO	
										TIM1_CH2	
										USART1_RX	
										MCO	
10	8	15	15	11	20	12	PA14 (SWCLK) ⁽²⁾	I/O	COM	SWCLK	-
										USART1_TX	
										USART2_TX	
										EVENTOUT	
										MCO	
-	-	-	-	-	-	-	PA15	I/O		SPI1_NSS	-
										USART1_RX	
										USART2_RX	
										LED_COM0	
										EVENTOUT	

Packages							Reset	Port type	Port structure	Functions	
QFN20 F1	QFN20 F2	QFN20 F3	TSSOP20 F1	TSSOP20 F2	TSSOP20 F3	TSSOP20 F4				Multiplexing	Additional
-	-	-	-	-	-	-	PB3	I/O		SPI1_SCK TIM1_CH2 USART1_RTS USART2_RTS EVENTOUT	COMP2_INM
11	-	16	16	-	-	13	PB4	I/O		SPI1_MISO TIM3_CH1 USART2_CTS USART1_CTS TIM17_BKIN EVENTOUT	COMP2_INP
12	9	17	17	12	-	-	PB5	I/O		SPI1_MOSI TIM3_CH2 TIM16_BKIN USART2_CK USART1_CK LPTIM_IN1 COMP1_OUT	-
-	10	18	18	13	-	-	PB6	I/O	COM	USART1_TX TIM1_CH3 TIM16_CH1N USART2_TX SPI2_MISO I ² C_SCL LPTIM_ETR EVENTOUT	COMP2_INP
13	11	19	19	14	-	-	PB7	I/O	COM	USART1_RX SPI2_MOSI TIM17_CH1N USART2_RX I ² C_SDA EVENTOUT	COMP2_INM PVD_IN
14	12	-	20	15	1	-	PF4-BOOT0	I/O	COM	-	BOOT0

Packages							Reset	Port type	Port structure	Functions	
QFN20 F1	QFN20 F2	QFN20 F3	TSSOP20 F1	TSSOP20 F2	TSSOP20 F3	TSSOP20 F4				Multiplexing	Additional
15	-	-	-	-	-	-	PB8	I/O	COM	SPI2_SCK	COMP1_INP
										TIM16_CH1	
										I ² C1_SCL	
										USART2_TX	
										EVENTOUT	
										USART1_TX	
										SPI2_NSS	
										I ² C_SDA	
										TIM17_CH1	
										IR_OUT	
-	-	-	-	-	-	-	V _{SS}	S		Ground	

1. Selecting PF2 or NRST is configured through option bytes .
2. After reset, the two pins of PA13 and PA14 are configured as SWDIO and SWCLK AF function, the former internal pull-up resistor, the latter internal pull-down resistor is activated.
3. PF4 -BOOT0 is the default digital input mode, and the pull-down is enabled.

Table 3-5 DFN8 pin definitions

Packages		Reset	Port type	Port structure	Functions	
DFN8 L1	Multiplexing				Additional	
1	VCC	S		Digital power supply		
2	PA0	I/O	COM	USART1_CTS COMP1_OUT TIM1_CH3 TIM1_CH1N SPI1_MISO IR_OUT	ADC_IN0 COMP1_INM	
3	PA1	I/O	COM	SPI1_SCK USART1_RTS EVENTOUT SPI1_MOSI TIM1_CH4 TIM1_CH2N MCO	COMP1_INP ADC_IN1	
4	PA2	I/O	COM	SPI1_MOSI USART1_TX COMP2_OUT SPI1_SCK TIM3_CH1 I2C_SDA	COMP2_INM ADC_IN2	
5	PF2-NRST	I/O	RST (1) (3) (4)	MCO	NRST	
5	PB0	I/O	COM (3) (4)	SPI1_NSS TIM3_CH3 TIM1_CH2N EVENTOUT COMP1_OUT	ADC_IN8	
6	PA10	I/O	COM ⁽³⁾	USART1_RX TIM1_CH3 TIM17_BKIN I2C_SDA EVENTOUT I2C_SCL SPI1_NSS USART1_TX IR_OUT	OS32IN	
6	PA13(SWDIO)	I/O	COM (2) (3)	SWDIO IR_OUT EVENTOUT SPI1_MISO TIM1_CH2 USART1_RX MCO	-	

Packages		Reset	Port type	Port structure	Functions	
DFN8 L1	Multiplexing				Additional	
7	PA14(SWCLK)	I/O	COM (2) (3)	SWCLK USART1_TX EVENTOUT MCO	-	
7	PB6	I/O	COM ⁽³⁾	USART1_TX TIM1_CH3 TIM16_CH1N I2C_SCL LPTIM_ETR EVENTOUT	COMP2_INP	
8	PB5	I/O	COM	SPI1_MOSI TIM3_CH2 TIM16_BKIN USART1_CK LPTIM_IN1 COMP1_OUT	-	

1. Selecting PF2 or NRST is configured through option bytes .
2. After reset, the two pins of PA13 and PA14 are configured as SWDIO and SWCLK AF function, the former internal pull-up resistor, the latter internal pull-down resistor is activated.
3. PF4 -BOOT0 is the default digital input mode, and the pull-down is enabled.
4. Both IO ports lead out on the same pin, only either IO port can be used at the same time, and the other IO must be configured in analog mode (MODEy[1:0] is 0B11).

3.1. Port A multiplexing function mapping

Port	AF0	AF1	AF2	AF3	AF4	AF5	AF6	AF7
PA0	SPI2_SCK	USART1_CTS	-	LED_DATA_B	USART2_CTS	-	-	COMP1_OUT
	AF8	AF9	AF10	AF11	AF12	AF13	AF14	AF15
	-	USART2_TX	SPI1_MISO	-	-	TIM1_CH3	TIM1_CH1N	IR_OUT
PA1	AF0	AF1	AF2	AF3	AF4	AF5	AF6	AF7
	SPI1_SCK	USART1_RTS	-	LED_DATA_C	USART2_RTS	-	-	EVENTOUT
	-	USART2_RX	SPI1_MOSI	-	-	TIM1_CH4	TIM1_CH2N	MCO
PA2	AF0	AF1	AF2	AF3	AF4	AF5	AF6	AF7
	SPI1_MOSI	USART1_TX	-	LED_DATA_D	USART2_TX	-	-	COMP2_OUT
	-	-	SPI1_SCK	-	I ² C_SDA	TIM3_CH1	-	-
PA3	AF0	AF1	AF2	AF3	AF4	AF5	AF6	AF7
	SPI2_MISO	USART1_RX	-	LED_DATA_E	USART2_RX	-	-	EVENTOUT
	-	-	SPI1_MOSI	-	I ² C_SCL	TIM1_CH1	-	-
PA4	AF0	AF1	AF2	AF3	AF4	AF5	AF6	AF7
	SPI1_NSS	USART1_CK	SPI2_MOSI	LED_DATA_F	TIM14_CH1	USART2_CK	-	EVENTOUT
	-	USART2_TX	-	-	-	TIM3_CH3	-	RTC_OUT
PA5	AF0	AF1	AF2	AF3	AF4	AF5	AF6	AF7
	SPI1_SCK	-	-	LED_DATA_G	-	LPTIM1_ETR	-	EVENTOUT
	-	USART2_RX	-	-	-	TIM3_CH2	-	MCO
PA6	AF0	AF1	AF2	AF3	AF4	AF5	AF6	AF7
	SPI1_MISO	TIM3_CH1	TIM1_BKIN	LED_DATA_DP	-	TIM16_CH1	-	COMP1_OUT
	USART1_CK	-	-	-	-	-	-	RTC_OUT
PA7	AF0	AF1	AF2	AF3	AF4	AF5	AF6	AF7
	SPI1_MOSI	TIM3_CH2	TIM1_CH1N	-	TIM14_CH1	TIM17_CH1	EVENTOUT	COMP2_OUT
	USART1_TX	USART2_TX	SPI1_MISO	-	I ² C_SDA	-	-	-
PA8	AF0	AF1	AF2	AF3	AF4	AF5	AF6	AF7
	SPI2_NSS	USART1_CK	TIM1_CH1	-	USART2_CK	MCO	-	EVENTOUT
	AF8	AF9	AF10	AF11	AF12	AF13	AF14	AF15
PA9	AF0	AF1	AF2	AF3	AF4	AF5	AF6	AF7
	SPI2_MISO	USART1_TX	TIM1_CH2	-	USART2_TX	MCO	I ² C_SCL	EVENTOUT
	USART1_RX	-	SPI1_SCK	-	I ² C_SDA	TIM1_BKIN	-	-
PA10	AF0	AF1	AF2	AF3	AF4	AF5	AF6	AF7
	SPI2_MOSI	USART1_RX	TIM1_CH3	-	USART2_RX	TIM17_BKIN	I ² C_SDA	EVENTOUT
	AF8	AF9	AF10	AF11	AF12	AF13	AF14	AF15
PA11	AF0	AF1	AF2	AF3	AF4	AF5	AF6	AF7
	SPI1_MISO	USART1_CTS	TIM1_CH4	-	USART2_CTS	EVENTOUT	I ² C_SCL	COMP1_OUT
	AF8	AF9	AF10	AF11	AF12	AF13	AF14	AF15
PA12	AF0	AF1	AF2	AF3	AF4	AF5	AF6	AF7
	SPI1_MOSI	USART1_RTS	TIM1_ETR	-	USART2_RTS	EVENTOUT	I ² C_SDA	COMP2_OUT
	AF8	AF9	AF10	AF11	AF12	AF13	AF14	AF15
PA13	AF0	AF1	AF2	AF3	AF4	AF5	AF6	AF7
	SWDIO	IR_OUT	-	-	-	-	-	EVENTOUT
	USART1_RX	-	SPI1_MISO	-	-	TIM1_CH2	-	MCO
PA14	AF0	AF1	AF2	AF3	AF4	AF5	AF6	AF7
	SWCLK	USART1_TX	-	-	USART2_TX	-	-	EVENTOUT
	-	-	-	-	-	-	-	MCO
PA15	AF0	AF1	AF2	AF3	AF4	AF5	AF6	AF7
	SPI1_NSS	USART1_RX	-	-	USART2_RX	-	LED_COM0	EVENTOUT

3.2. Port B multiplexing function mapping

Port	AF0	AF1	AF2	AF3	AF4	AF5	AF6	AF7
PB0	SPI1_NSS	TIM3_CH3	TIM1_CH2N	-	-	EVENTOUT	-	COMP1_OUT
PB1	AF0	AF1	AF2	AF3	AF4	AF5	AF6	AF7
	TIM14_CH1	TIM3_CH4	TIM1_CH3N	-	-	-	-	EVENTOUT
PB2	AF0	AF1	AF2	AF3	AF4	AF5	AF6	AF7
	USART1_RX	SPI2_SCK	-	USART2_RX	-	-	-	-
PB3	AF0	AF1	AF2	AF3	AF4	AF5	AF6	AF7
	SPI1_SCK	TIM1_CH2	-	USART1_RTS	USART2_RTS	-	LED_COM1	EVENTOUT
PB4	AF0	AF1	AF2	AF3	AF4	AF5	AF6	AF7
	SPI1_MISO	TIM3_CH1	-	USART1_CTS	USART2_CTS	TIM17_BKIN	LED_COM2	EVENTOUT
PB5	AF0	AF1	AF2	AF3	AF4	AF5	AF6	AF7
	SPI1_MOSI	TIM3_CH2	TIM16_BKIN	USART1_CK	USART2_CK	LPTIM_IN1	LED_COM3	COMP1_OUT
PB6	AF0	AF1	AF2	AF3	AF4	AF5	AF6	AF7
	USART1_TX	TIM1_CH3	TIM16_CH1N	SPI2_MISO	USART2_TX	LPTIM_ETR	I ² C_SCL	EVENTOUT
PB7	AF0	AF1	AF2	AF3	AF4	AF5	AF6	AF7
	USART1_RX	SPI2_MOSI	TIM17_CH1N	-	USART2_RX	-	I ² C_SDA	EVENTOUT
PB8	AF0	AF1	AF2	AF3	AF4	AF5	AF6	AF7
	-	SPI2_SCK	TIM16_CH1	LED_DATA_A	USART2_TX	-	I ² C_SCL	EVENTOUT
	AF8	AF9	AF10	AF11	AF12	AF13	AF14	AF15
	USART1_TX	-	-	SPI2_NSS	I ² C_SDA	TIM17_CH1	-	IR_OUT

3.3. Port F multiplexing function mapping

Port	AF0	AF1	AF2	AF3	AF4	AF5	AF6	AF7
PF0-OSC_IN	-	-	TIM14_CH1	SPI2_SCK	USART2_RX	-	-	-
	AF8	AF9	AF10	AF11	AF12	AF13	AF14	AF15
	USART1_RX	USART2_TX	-	-	I ² C_SDA	-	-	-
PF1-OSC_OUT	AF0	AF1	AF2	AF3	AF4	AF5	AF6	AF7
	-	-	-	SPI2_MISO	USART2_TX	-	-	-
	AF8	AF9	AF10	AF11	AF12	AF13	AF14	AF15
	USART1_TX	USART2_RX	SPI1_NSS	-	I ² C_SCL	TIM14_CH1	-	-
PF2-NRST	AF0	AF1	AF2	AF3	AF4	AF5	AF6	AF7
	-	-	-	SPI2_MOSI	USART2_RX	-	MCO	-
PF3	AF0	AF1	AF2	AF3	AF4	AF5	AF6	AF7
	USART1_TX	-	-	SPI2_MISO	USART2_TX	-	-	-
	AF8	AF9	AF10	AF11	AF12	AF13	AF14	AF15
	-	-	SPI1_NSS	-	-	TIM3_CH3	-	RTC_OUT
PF4-BOOT0	AF0	AF1	AF2	AF3	AF4	AF5	AF6	AF7
	-	-	-	-	-	-	-	-

4. Memory Map

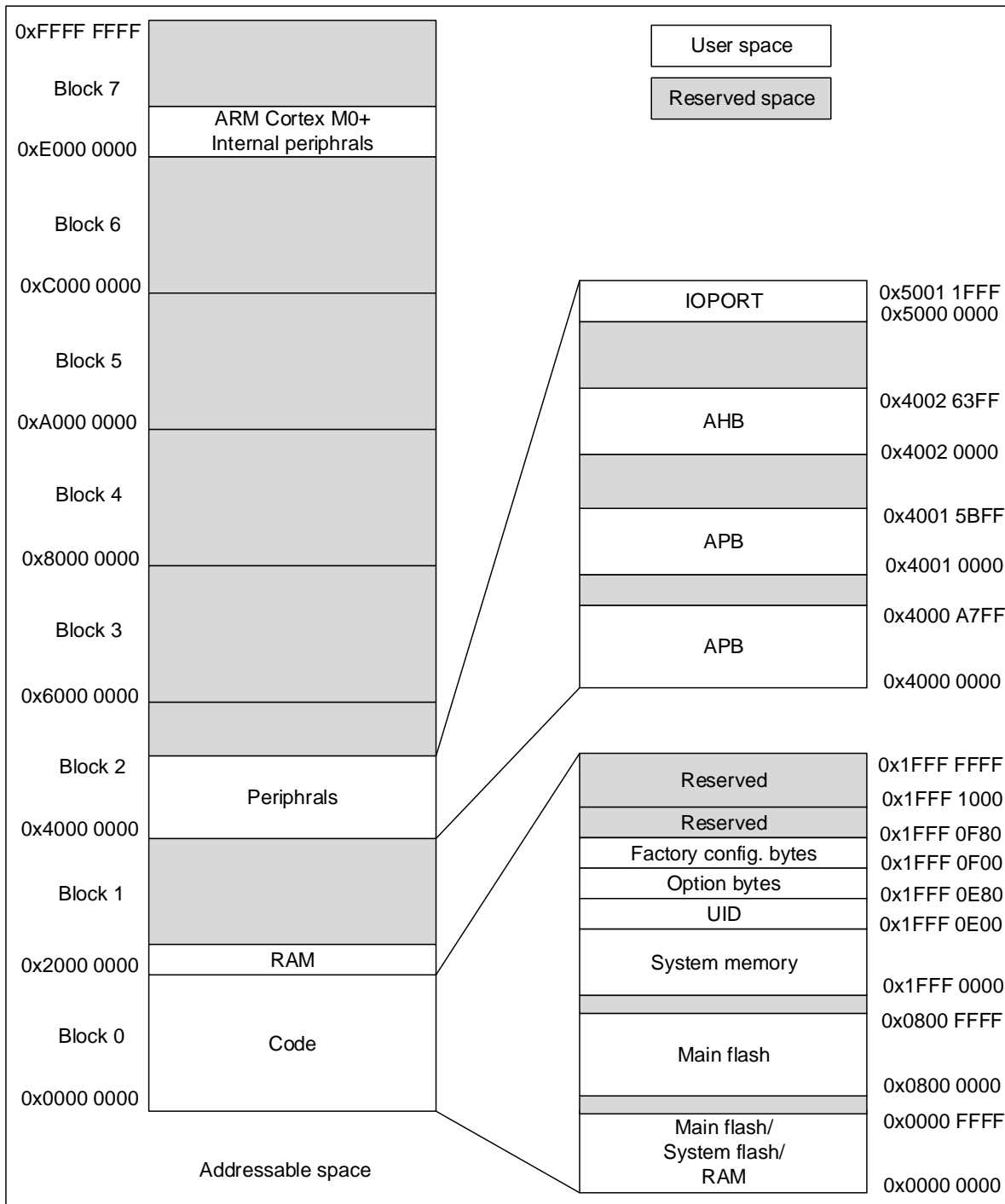

Figure 4-1 Memory map

Table 4-1 Memory address

Type	Boundary Address	Size	Memory Area	Description
SRAM	0x2000 2000-0x3FFF FFFF	-	Reserved	-
	0x2000 0000-0x2000 1FFF	8 KB	SRAM	SRAM up to 8 KB depending on hardware
Code	0x1FFF 1000-0x1FFF FFFF	-	Reserved	-
	0x1FFF 0F80-0x1FFF 0FFF	-	Reserved	-
	0x1FFF 0F00-0x1FFF 0F7F	128 Bytes	Factory config	Storage of HSI trimming data, flash erase time configuration parameters
	0x1FFF 0E80-0x1FFF 0EFF	128 Bytes	Option bytes	option bytes
	0x1FFF 0E00-0x1FFF 0E7F	128 Bytes	UID	Unique ID
	0x1FFF 0000-0x1FFF 0DFF	3.5 KB	System memory	Storage boot loader
	0x0801 0000-0x1FFF FFFF	-	Reserved	-
	0x0800 0000-0x0800 FFFF	64 KB	Main flash memory	-
	0x0001 0000-0x07FF FFFF	-	Reserved	-
	0x0000 0000-0x0000 FFFF	64 KB	Select based on Boot configuration: 1) Main flash memory 2) System memory 3) SRAM	-

1. Except for 0x1FFF 0E00-0x1FFF 0E7F, the above spaces are marked as Reserved spaces, which cannot be written and read as 0 with response error.

Table 4-2 Peripheral register address

Bus	Boundary Address	Size	Peripheral
	0xE000 0000-0xE00F FFFF	1 MB	M0+
IOPORT	0x5000 1800-0x5FFF FFFF	-	Reserved ⁽¹⁾
	0x5000 1400-0x5000 17FF	1 KB	GPIOF
	0x5000 1000-0x5000 13FF	-	Reserved
	0x5000 0C00-0x5000 0FFF	-	Reserved
	0x5000 0800-0x5000 0BFF	-	Reserved
	0x5000 0400-0x5000 07FF	1 KB	GPIOB
	0x5000 0000-0x5000 03FF	1 KB	GPIOA
AHB	0x4002 3400-0x4FFF FFFF	-	Reserved
	0x4002 300C-0x4002 33FF	1 KB	Reserved
	0x4002 3000-0x4002 3008		CRC
	0x4002 2400-0x4002 2FFF	-	Reserved
	0x4002 2124-0x4002 23FF	1 KB	Reserved
	0x4002 2000-0x4002 2120		Flash
	0x4002 1C00-0x4002 1FFF	-	Reserved
	0x4002 1888-0x4002 1BFF	1 KB	Reserved
	0x4002 1800-0x4002 1884		EXTI ⁽²⁾
	0x4002 1400-0x4002 17FF	-	Reserved
	0x4002 1064-0x4002 13FF	1 KB	Reserved

Bus	Boundary Address	Size	Peripheral
	0x4002 1000-0x4002 1060		RCC ⁽²⁾
	0x4002 0C00-0x4002 0FFF	1 KB	Reserved
	0x4002 0040-0x4002 03FF	1 KB	Reserved
	0x4002 0000-0x4002 003C		DMA
APB	0x4001 5C00-0x4001 FFFF	-	Reserved
	0x4001 5880-0x4001 5BFF	1 KB	Reserved
	0x4001 5800-0x4001 587F		DBG
	0x4001 4C00-0x4001 57FF	-	Reserved
	0x4001 4850-0x4001 4BFF	1 KB	Reserved
	0x4001 4800-0x4001 484C		TIM17
	0x4001 4450-0x4001 47FF	1 KB	Reserved
	0x4001 4400-0x4001 404C		TIM16
	0x4001 3C00-0x4001 43FF	-	Reserved
	0x4001 381C-0x4001 3BFF	1 KB	Reserved
	0x4001 3800-0x4001 3018		USART1
	0x4001 3400-0x4001 37FF	-	Reserved
	0x4001 3010-0x4001 33FF	1 KB	Reserved
	0x4001 3000-0x4001 300C		SPI1
	0x4001 2C50-0x4001 2FFF	1 KB	Reserved
	0x4001 2C00-0x4001 2C4C		TIM1
	0x4001 2800-0x4001 2BFF	-	Reserved
	0x4001 270C-0x4001 27FF	1 KB	Reserved
	0x4001 2400-0x4001 2708		ADC
	0x4001 0400-0x4001 23FF	-	Reserved
	0x4001 0220-0x4001 03FF	1 KB	Reserved
	0x4001 0200-0x4001 021F		COMP1 and COMP2
	0x4001 0000-0x4001 01FF		SYSCFG
	0x4000 B400-0x4000 FFFF	-	Reserved
	0x4000 B000-0x4000 B3FF	-	Reserved
	0x4000 8400-0x4000 AFFF	-	Reserved
	0x4000 8000-0x4000 83FF	1 KB	Reserved
	0x4000 7C28-0x4000 7FFF	1 KB	Reserved
	0x4000 7C00-0x4000 7C24		LPTIM
	0x4000 7400-0x4000 7BFF	-	Reserved
	0x4000 7018-0x4000 73FF	1 KB	Reserved
	0x4000 7000-0x4000 7014		PWR ⁽³⁾
	0x4000 5800-0x4000 6FFF	-	Reserved
	0x4000 5434-0x4000 57FF	1 KB	Reserved
	0x4000 5400-0x4000 5430		I ² C
	0x4000 4800-0x4000 53FF	-	Reserved

Bus	Boundary Address	Size	Peripheral
	0x4000 441C-0x4000 47FF	1 KB	Reserved
	0x4000 4400-0x4000 4418		USART2
	0x4000 3C00-0x4000 43FF	-	Reserved
	0x4000 3810-0x4000 3BFF	1 KB	Reserved
	0x4000 3800-0x4000 380C		SPI2
	0x4000 3400-0x4000 37FF	-	Reserved
	0x4000 3014-0x4000 33FF	1 KB	Reserved
	0x4000 3000-0x4000 0010		IWDG
	0x4000 2C0C-0x4000 2FFF	1 KB	Reserved
	0x4000 2C00-0x4000 2C08		WWDG
	0x4000 2830-0x4000 2BFF	1 KB	Reserved
	0x4000 2800-0x4000 282C		RTC ⁽³⁾
	0x4000 2420-0x4000 27FF	1 KB	Reserved
	0x4000 2400-0x4000 241C		LED
	0x4000 2054-0x4000 23FF	1 KB	Reserved
	0x4000 2000-0x4000 0050		TIM14
	0x4000 1800-0x4000 1FFF	-	Reserved
	0x4000 1400-0x4000 17FF	-	Reserved
	0x4000 1030-0x4000 13FF	1 KB	Reserved
	0x4000 1000-0x4000 102C		Reserved
	0x4000 0800-0x4000 0FFF	-	Reserved
	0x4000 0450-0x4000 07FF	1 KB	Reserved
	0x4000 0400-0x4000 044C		TIM3
	0x4000 0000-0x4000 03FF	1 KB	Reserved

1. The address space marked as Reserved by AHB in the above table cannot be written, read is 0, and a hardfault is generated. The address space marked as Reserved by APB cannot be written, read back as 0, but no hardfault will be generated.
2. Not only supports 32 bits word access, but also supports halfword and byte access.
3. Not only supports 32 bits word access, but also supports halfword and byte access.

5. Electrical Characteristics

5.1. Test conditions

All voltages are referenced to V_{SS} unless otherwise specified.

5.1.1. Min and Max

Unless otherwise specified, the chip is screened by mass production testing at ambient temperature $T_A = 25^\circ\text{C}$ and $T_A = T_{A(\text{max})}$, guaranteed to reach the minimum value and maximum value under the worst ambient temperature, supply voltage and clock frequency conditions.

Based on electrical characterization results, design simulations, and/or process parameters noted below the table, not tested in production. Minimum and maximum values are referenced to sample testing and averaged plus or minus three times the standard deviation.

5.1.2. Typical value

Unless otherwise specified, typical data is based on $T_A = 25^\circ\text{C}$ and $V_{CC} = 3.3\text{ V}$. These data are for design guidance only and have not been tested.

Typical ADC accuracy values are obtained by sampling a standard batch, tested under all temperature ranges, and 95% of the chip error is less than or equal to the given value.

5.2. Absolute maximum ratings

If the applied voltage exceeds the absolute maximum value given in the table below, it may cause permanent damage to the chip. Only the strength ratings that can be tolerated are listed here, and it does not imply that the functional operation of the device is correct under these conditions. Operating under maximum conditions for a long time may affect the reliability of the chip.

Table 5-1 Voltage characteristics ⁽¹⁾

Symbol	Describe	Min	Max	Unit
V_{CC}	External mains power supply	-0.3	6.25	V
V_{IN}	Input voltage of other pins	-0.3	$V_{CC} + 0.3$	V

1. Power supply V_{CC} and ground V_{SS} pins must always be connected to the external power supply within the allowable range.

Table 5-2 Current characteristics

Symbol	Describe	Max	Unit
I_{VCC}	Flowing into V_{CC} pin (supply current) ⁽¹⁾	100	mA
I_{VSS}	Total current flowing out of V_{SS} pin (outflow current) ⁽¹⁾	100	
$I_{IO(\text{PIN})}$	Output sink current of COM IO ⁽²⁾	20	
	Output sink current COM_L IO ⁽²⁾	80	
	Source current for all IOs	- 20	

1. Power supply V_{CC} and ground V_{SS} pins must always be connected to the external power supply within the allowable range.
2. IO types can refer to pin definition terminology and symbols.

Table 5-3 Temperature characteristics

Symbol	Describe	Condition	Value	Unit
T_{STG}	Storage temperature range		-65 ~ +150	$^\circ\text{C}$
T_O	Range of operating temperature	x6 version	-40 ~ +85	$^\circ\text{C}$
		x7 version	- 40 ~ +105	

5.3. Operating conditions

5.3.1. General operating conditions

Table 5-4 General operating conditions

Symbol	Parameter	Condition	Min	Max	Unit
f _{HCLK}	Internal AHB clock frequency	-	0	48	MHz
f _{PCLK}	Internal APB Clock Frequency	-	0	48	MHz
V _{CC}	Standard operating voltage	x6 version	1.7	5.5	V
		x7 version	2.0	5.5	
V _{IN}	IO input voltage	-	-0.3	V _{CC} +0.3	V
T _A	Ambient temperature	x6 version	-40	85	°C
		x7 version	-40	105	
T _J	Junction temperature	x6 version	-40	90	°C
		x7 version	-40	110	

5.3.2. Operating conditions at power-up / power-down

Table 5-5 Operating conditions at power-up / power-down

Symbol	Parameter	Condition	Min	Max	Unit
t _{vcc}	V _{CC} rise rate	-	0	∞	us/V
	V _{CC} fall rate	-	20	∞	

5.3.3. Embedded reset and PVD module characteristics

Table 5-6 Embedded reset and PVD module characteristics

Symbol	Parameter	Condition	Min	Typical	Max	Unit
t _{rsttempo} ⁽¹⁾	Reset time	-	-	4.0	7.5	ms
V _{POR/PDR}	POR/PDR reset threshold	rising edge	1.50 ⁽²⁾	1.60	1.70	V
		falling edge	1.45 ⁽¹⁾	1.55	1.65 ⁽²⁾	V
V _{BOR1}	BOR threshold 1	rising edge	1.70 ⁽²⁾	1.80	1.90	V
		falling edge	1.60	1.70	1.80 ⁽²⁾	V
V _{BOR2}	BOR threshold 2	rising edge	1.90 ⁽²⁾	2.00	2.10	V
		falling edge	1.80	1.90	2.00 ⁽²⁾	V
V _{BOR3}	BOR threshold 3	rising edge	2.10 ⁽²⁾	2.20	2.30	V
		falling edge	2.00	2.10	2.20 ⁽²⁾	V
V _{BOR4}	BOR threshold 4	rising edge	2.30 ⁽²⁾	2.40	2.50	V
		falling edge	2.20	2.30	2.40 ⁽²⁾	V
V _{BOR5}	BOR threshold 5	rising edge	2.50 ⁽²⁾	2.60	2.70	V
		falling edge	2.40	2.50	2.60 ⁽²⁾	V
V _{BOR6}	BOR threshold 6	rising edge	2.70 ⁽²⁾	2.80	2.90	V
		falling edge	2.60	2.70	2.80 ⁽²⁾	V
V _{BOR7}	BOR threshold 7	rising edge	2.90 ⁽²⁾	3.00	3.10	V
		falling edge	2.80	2.90	3.00 ⁽²⁾	V
V _{BOR8}	BOR threshold 8	rising edge	3.10 ⁽²⁾	3.20	3.30	V

Symbol	Parameter	Condition	Min	Typical	Max	Unit
		falling edge	3.00	3.10	3.20 ⁽²⁾	V
V _{PVD0}	PVD threshold 0	rising edge	1.70 ⁽²⁾	1.80	1.90	V
		falling edge	1.60	1.70	1.80 ⁽²⁾	V
V _{PVD1}	PVD Threshold 1	rising edge	1.90 ⁽²⁾	2.00	2.10	V
		falling edge	1.80	1.90	2.00 ⁽²⁾	V
V _{PVD2}	PVD Threshold 2	rising edge	2.10 ⁽²⁾	2.20	2.30	V
		falling edge	2.00	2.10	2.20 ⁽²⁾	V
V _{PVD3}	PVD Threshold 3	rising edge	2.30 ⁽²⁾	2.40	2.50	V
		falling edge	2.20	2.30	2.40 ⁽²⁾	V
V _{PVD4}	PVD Threshold 4	rising edge	2.50 ⁽²⁾	2.60	2.70	V
		falling edge	2.40	2.50	2.60 ⁽²⁾	V
V _{PVD5}	PVD threshold 5	rising edge	2.70 ⁽²⁾	2.80	2.90	V
		falling edge	2.60	2.70	2.80 ⁽²⁾	V
V _{PVD6}	PVD threshold 6	rising edge	2.90 ⁽²⁾	3.00	3.10	V
		falling edge	2.80	2.90	3.00 ⁽²⁾	V
V _{PVD7}	PVD threshold 7	rising edge	3.10 ⁽²⁾	3.20	3.30	V
		falling edge	3.00	3.10	3.20 ⁽²⁾	V
V _{POR_PDR_hyst} ⁽¹⁾	POR / PDR hysteresis voltage	-	-	50	-	mV
V _{PVD_BOR_hyst} ⁽¹⁾	PVD hysteresis voltage	-	-	100	-	mV
I _{CC(PVD)}	PVD power consumption	-	-	0.6	-	uA
I _{CC(BOR)}	BOR power consumption	-	-	0.6	-	uA

1. Guaranteed by design, not tested in production.
2. Data is based on assessment results and is not tested in production.

5.3.4. Operating current characteristics

Table 5-7 Current consumption in run mode

Symbol	Condition						Typ ⁽¹⁾	Max	Unit	
	System clock	Frequency	Code	Run	Peripheral clock	Flash sleep				
I _{CC(run)}	PLL	48 MHz	While(1)	Flash	ON	DISABLE	2.60	-	mA	
					OFF	DISABLE	1.70	-		
	HSI	24 MHz			ON	DISABLE	1.50	-		
					OFF	DISABLE	0.90	-		
		16 MHz			ON	DISABLE	1.10	-		
					OFF	DISABLE	0.70	-		
		8 MHz			ON	DISABLE	0.70	-		
					OFF	DISABLE	0.50	-		
	4 MHz	ON			DISABLE	0.50	-			
		OFF			DISABLE	0.35	-			
	LSI	32.768 kHz			ON	DISABLE	170	-		uA
					OFF	DISABLE	170	-		

Symbol	Condition					Typ ⁽¹⁾	Max	Unit	
	System clock	Frequency	Code	Run	Peripheral clock				Flash sleep
	LSI	32.768 kHz			ON	ENABLE	95.0	-	uA
					OFF	ENABLE	95.0	-	

1. Data is based on assessment results and is not tested in production.

Table 5-8 Current consumption in sleep mode

Symbol	Condition				Typ ⁽¹⁾	Max	Unit
	System clock	Frequency	Peripheral clock	Flash sleep			
I _{cc(sleep)}	PLL	48 MHz	ON	DISABLE	1.80	-	mA
			OFF	DISABLE	1.10	-	
	HSI	24 MHz	ON	DISABLE	1.00	-	mA
			OFF	DISABLE	0.60	-	
		16 MHz	ON	DISABLE	0.75	-	
			OFF	DISABLE	0.50	-	
		8 MHz	ON	DISABLE	0.50	-	
			OFF	DISABLE	0.35	-	
		4 MHz	ON	DISABLE	0.40	-	
			OFF	DISABLE	0.35	-	
	LSI	32.768 kHz	ON	DISABLE	1700	-	uA
			OFF	DISABLE	1700	-	
		32.768 kHz	ON	ENABLE	95.0	-	
			OFF	ENABLE	96.0	-	

1. Data is based on assessment results and is not tested in production.

Table 5-9 Current consumption in stop modet

Symbol	Condition					Typ ⁽¹⁾	Max	Unit
	V _{CC}	V _{DD}	MR/LPR	LSI	Peripheral clock			
I _{cc(stop)}	1.7 ~ 5.5 V	1.2 V	MR	-	-	70.0	-	uA
		1.2 V	LPR	ON	RTC+IWDG+LPTIM	6.00	-	
					IWDG	6.00	-	
					LPTIM	6.00	-	
				OFF	RTC	6.00	-	
					No	6.00	-	
					RTC+IWDG+LPTIM	4.50	-	
		1.0 V	LPR	ON	IWDG	4.50	-	
					LPTIM	4.50	-	
					RTC	4.50	-	
				OFF	No	4.50	-	

1. Data is based on assessment results and is not tested in production.

5.3.5. Wakeup time from low-power modes

Table 5-10 Wakeup time from low-power modes

Symbol	Parameters ⁽¹⁾	Condition	Typ ⁽²⁾	Max	Unit
t _{WUSLEEP}	Wake-up time from sleep	-	1.65	-	us

Symbol	Parameters ⁽¹⁾		Condition	Typ ⁽²⁾	Max	Unit	
t _{WUSTOP}	Wake-up time from stop	Powered by MR	Execute program in Flash, HSI (24 MHz) as system clock	3.50	-	us	
		Powered by LPR	Execute program in Flash, HSI (24 MHz) as system clock	V _{DD} =1.2 V	6.00	-	us
				V _{DD} =1.0 V	6.00	-	

1. The wake-up time is measured from the wake-up time until the first instruction is read by the user program.
2. Data is based on assessment results and is not tested in production.

5.3.6. External clock source characteristics

5.3.6.1. External high-speed clock

In the bypass mode of HSE (the HSEBYP of RCC_CR is set), when the high-speed start-up circuit in the chip stops working, the corresponding IO is used as a standard GPIO.

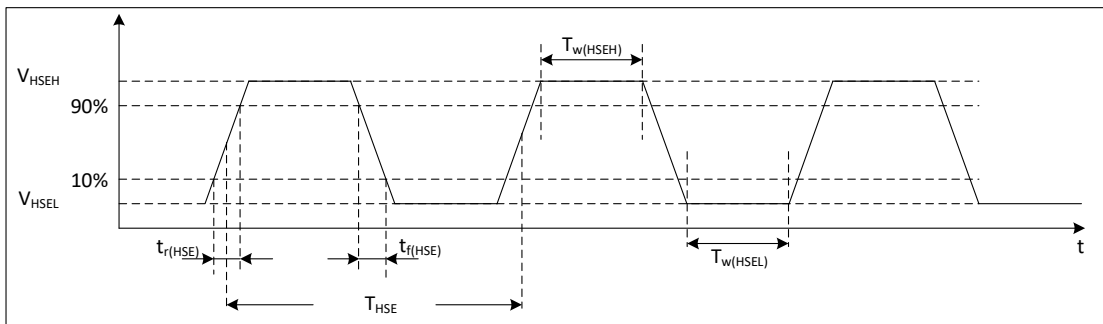

Figure 5-1 External high-speed clock timing diagram

Table 5-11 External high-speed clock characteristics

Symbol	Parameters ⁽¹⁾	Min	Typ	Max	Unit
f _{HSE_ext}	User external clock frequency	1	8	32	MHz
V _{HSEH}	Input pin high level voltage	0.7 V _{CC}	-	V _{CC}	V
V _{HSEL}	Input pin low level voltage	V _{SS}	-	0.3 V _{CC}	
t _{w(HSEH)} t _{w(HSEL)}	Enter high or low time	15	-	-	ns
t _{r(HSE)} t _{f(HSE)}	Enter the rise/fall time	-	-	20	ns

1. Guaranteed by design, not tested in production.

5.3.6.2. External low-speed clock

In LSE's bypass mode (RCC_BDCR LSEBYP position), the low-speed starter circuit within the chip stops working, and the corresponding IO is used as a standard GPIO.

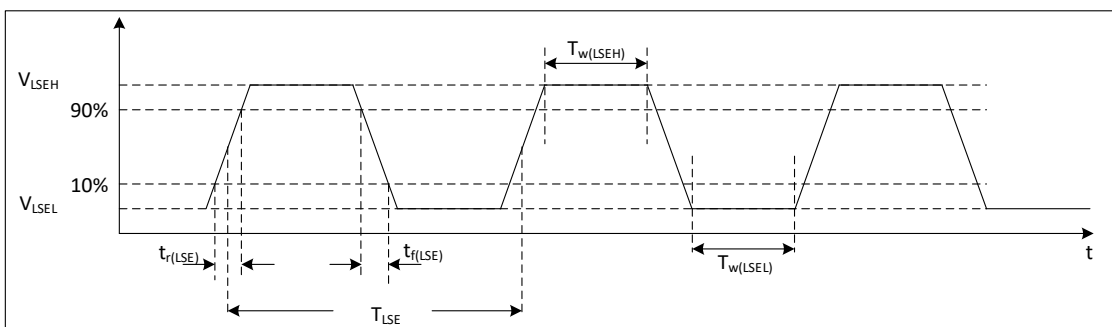

Figure 5-2 External low-speed clock timing diagram

Table 5-12 External high-speed clock characteristics

Symbol	Parameter ⁽¹⁾	Min	Typ	Max	Unit
f _{LSE_ext}	User external clock frequency	-	32.786	1000	kHz
V _{LSEH}	Input pin high level voltage	0.7V _{CC}	-	-	V
V _{LSEL}	Input pin low level voltage	-	-	0.3V _{CC}	
t _{W(LSEH)} t _{W(LSEL)}	Enter high or low time	450	-	-	ns
t _{r(LSE)} t _{f(LSE)}	Enter the rise/fall time	-	-	50	ns

1. Guaranteed by design, not tested in production.

5.3.6.3. External high-speed crystal

An external 4 ~ 32MHz crystal/ceramic resonator. In the application, the crystal and load capacitors should be as close as possible to the pins to minimize output distortion and start-up settling time.

Table 5-13 External high-speed crystal characteristics

Symbol	Parameter	Condition ⁽¹⁾	Min ⁽²⁾	Typ	Max ⁽²⁾	Unit
f _{OSC_IN}	Oscillation frequency	-	4	-	32	MHz
I _{CC} ⁽⁴⁾	HSE power consumption	During startup	-	-	5.5	mA
		V _{CC} =3 V, R _m =30 Ω, C _L =10 pF@8 MHz	-	0.58	-	
		V _{CC} =3 V, R _m =45 Ω, C _L =10 pF@8 MHz	-	0.59	-	
		V _{CC} =3 V, R _m =30 Ω, C _L =5 pF@48 MHz	-	0.89	-	
		V _{CC} =3 V, R _m =30 Ω, C _L =10 pF@48 MHz	-	1.14	-	
		V _{CC} =3 V, R _m =30 Ω, C _L =20 pF@48 MHz	-	1.94	-	
t _{SU (HSE)} ^{(3) (4)}	Start Time	f _{OSC_IN} =32 MHz	-	3	-	ms
		f _{OSC_IN} =4 MHz	-	15	-	

1. Crystal/ceramic resonator characteristics are based on the manufacturer datasheet.

2. Guaranteed by design, not tested in production.

3. t_{SU(HSE)} is the start-up time from enable (by software) to the clock oscillation reaches stability, measured for a standard crystal/resonator, which can vary greatly from one crystal/resonator to another .

4. Data is based on assessment results and is not tested in production.

5.3.6.4. External low-speed crystal

An external 32.768 kHz crystal/ceramic resonator can be used. In the application, the crystal and load capacitors should be as close as possible to the pins to minimize output distortion and start-up settling time.

Table 5-14 External high-speed crystal characteristics

Symbol	Parameter	Condition ⁽¹⁾	Min ⁽²⁾	Typ	Max ⁽²⁾	Unit
I _{CC} ⁽⁴⁾	LSE power consumption	LSE_DRIVER [1:0] = 00	-	-	-	nA
		LSE_DRIVER [1:0] = 01	-	560	-	
		LSE_DRIVER [1:0] = 10	-	920	-	
		LSE_DRIVER [1:0] = 11	-	1260	-	
t _{SU(LSE)} ^{(3) (4)}	Start Time	-	-	3	-	s

1. Crystal/ceramic resonator characteristics are based on the manufacturer datasheet.
2. Guaranteed by design, not tested in production.
3. $t_{SU(LSE)}$ is the start-up time from enable (by software) to the clock oscillation reaches stability, measured for a standard crystal/resonator, which can vary greatly from one crystal/resonator to another .
4. Data is based on assessment results and is not tested in production.

5.3.7. Internal high frequency clock source HSI characteristics

Table 5-15 Internal high frequency clock source characteristics

Symbol	Parameter	Condition	Min	Typ	Max	Unit
f_{HSI}	HSI frequency	$T_A=25^{\circ}\text{C}, V_{CC}=3.3\text{ V}$	23.83 ⁽²⁾	24.00	24.17 ⁽²⁾	MHz
			21.97 ⁽²⁾	22.12	22.27 ⁽²⁾	
			15.89 ⁽²⁾	16.00	16.11 ⁽²⁾	
			7.94 ⁽²⁾	8.00	8.06 ⁽²⁾	
			3.97 ⁽²⁾	4.00	4.03 ⁽²⁾	
$\Delta_{Temp(HSI)}$	HSI frequency temperature drift	$T_A=0 \sim 85^{\circ}\text{C}$	-2 ⁽²⁾	-	2 ⁽²⁾	%
		$T_A=-40 \sim 85^{\circ}\text{C}$	-4 ⁽²⁾	-	2 ⁽²⁾	
		$T_A=-40 \sim 105^{\circ}\text{C}$	-4 ⁽²⁾	-	2.5 ⁽²⁾	
$f_{TRIM}^{(1)}$	HSI fine-tuning accuracy	-	-	0.1	-	%
$D_{HSI}^{(1)}$	Duty cycle	-	45 ⁽¹⁾	-	55 ⁽¹⁾	%
$t_{Stab(HSI)}$	HSI stabilization time	-	-	2	4 ⁽¹⁾	us
$I_{CC(HSI)}^{(2)}$	HSI power consumption	4 MHz	-	100	-	uA
		8 MHz	-	105	-	
		16 MHz	-	150	-	
		22.12 MHz, 24 MHz	-	180	-	

1. Guaranteed by design, not tested in production.
2. Data is based on assessment results and is not tested in production.

5.3.8. Internal low frequency clock source LSI characteristics

Table 5-16 Internal low frequency clock characteristics

Symbol	Parameter	Condition	Min	Typ	Max	Unit
f_{LSI}	LSI frequency	$T_A=25^{\circ}\text{C}, V_{CC}=3.3\text{ V}$	-3	-	+3	%
$\Delta_{Temp(LSI)}$	LSI frequency temperature drift	$T_A=0 \sim 85^{\circ}\text{C}$	-10 ⁽²⁾	-	10 ⁽²⁾	%
		$T_A=-40 \sim 105^{\circ}\text{C}$	-20 ⁽²⁾	-	20 ⁽²⁾	
$f_{TRIM}^{(1)}$	LSI fine-tuning accuracy	-	-	0.2	-	%
$t_{Stab(LSI)}^{(1)}$	LSI stabilization time	-	-	150	-	us
$I_{CC(LSI)}^{(1)}$	LSI power consumption	-	-	210	-	nA

1. Guaranteed by design, not tested in production.
2. Data is based on assessment results and is not tested in production.

5.3.9. Phase-locked loop PLL characteristics

Table 5-17 Phase-locked loop characteristics

Symbol	Parameter	Condition	Min		Typ	Max	Unit	
			Default	- E ⁽²⁾				
f_{PLL_IN}	Enter the frequency	$T_A=25^{\circ}\text{C}, V_{CC}=3.3\text{ V}$	x6 version	16 ⁽¹⁾	24	-	24 ⁽¹⁾	MHz
			x7 version	24	24	-	24	

Symbol	Parameter	Condition	Min		Typ	Max	Unit	
			Default	- E ⁽²⁾				
f _{PLL_OUT}	Output frequency	T _A =25 °C, V _{CC} =3.3 V	x6 version	32 ⁽¹⁾	48	-	48	MHz
			x7 version	48	-	-	48	
Jitter	Periodic jitter	-	-	-	-	0.3 ⁽¹⁾	ns	
t _{LOCK}	Latch time	f _{PLL_IN} =24 MHz	-	-	15	40 ⁽¹⁾	us	

1. Guaranteed by design, not tested in production.
2. -E refers to version E products; Default refers to non-E products.

5.3.10. Memory characteristics

Table 5-18 Memory characteristics

Symbol	Parameter	Condition	Typ	Max ⁽¹⁾	Unit
t _{prog}	Page program	-	1.0	1.5	ms
t _{ERASE}	Page/sector/mass erase	-	3.0	4.5	ms
I _{CC}	Page programe	-	2.1	2.9	mA
	Page/sector/mass erase	-	2.1	2.9	

1. Guaranteed by design, not tested in production.

Table 5-19 Memory erase times and data retention

Symbol	Parameter	Condition	Min ⁽¹⁾	Unit
N _{END}	Erase and write times	T _A = -40 ~ 85 °C	100	kcycle
		T _A = 85 ~ 105 °C	10	
t _{RET}	Data retention period	10 kcycle T _A = 55 °C	20	Year

1. Data is based on assessment results and is not tested in production.

5.3.11. EFT characteristics

Table 5-20 EFT characteristics

Symbol	Parameter	Condition	Grade	Typ	Unit
EFT to Power	-	IEC61000-4-4	A	4	kV

5.3.12. ESD & LU Characteristics

Table 5-21 ESD & LU characteristics

Symbol	Parameter	Condition	Typ	Unit
V _{ESD(HBM)}	Static Discharge Voltage (human body model)	ESDA/JEDEC JS-001-2017	6	kV
V _{ESD(CDM)}	Static Discharge Voltage (charging equipment model)	ESDA/JEDEC JS-002-2018	1	kV
LU	Static Latch-Up	JESD78E	200	mA

5.3.13. Port characteristics

Table 5-22 IO static characteristics

Symbol	Parameter	Condition	Min	Typ	Max	Unit
V _{IH}	Input high level voltage	V _{CC} =1.7 ~ 5.5 V	0.7 V _{CC}	-	-	V
V _{IL}	Input low level voltage	V _{CC} =1.7 ~ 5.5 V	-	-	0.3 V _{CC}	V
V _{hys} ⁽¹⁾	Schmitt hysteresis voltage	-	-	200	-	mV

Symbol	Parameter	Condition	Min	Typ	Max	Unit
I_{lkg}	Input leakage current	-	-	-	1	μA
R_{PU}	Pull-up resistor	-	30	50	70	$k\Omega$
R_{PD}	Pull-down resistor	-	30	50	70	$k\Omega$
$C_{IO}^{(1)}$	Pin capacitance	-	-	5	-	pF

1. Guaranteed by design, not tested in production.

Table 5-23 Output voltage characteristics

Symbol	Parameters ⁽¹⁾	condition	Min	Max	unit
V_{OL}	COM IO output low level	$I_{OL} = 8 \text{ mA}, V_{CC} \geq 2.7 \text{ V}$	-	0.4	V
		$I_{OL} = 4 \text{ mA}, V_{CC} = 1.8 \text{ V}$	-	0.5	
$V_{OL}^{(3)}$	COM_L IO ⁽²⁾ output low level	$I_{OL} = 20 \text{ mA}, V_{CC} \geq 2.7 \text{ V}$	-	0.7	V
		$I_{OL} = 10 \text{ mA}, V_{CC} = 1.8 \text{ V}$	-	0.6	
		$I_{OL} = 40 \text{ mA}, V_{CC} \geq 2.7 \text{ V}$	-	0.7	
		$I_{OL} = 20 \text{ mA}, V_{CC} = 1.8 \text{ V}$	-	0.6	
		$I_{OL} = 60 \text{ mA}, V_{CC} \geq 2.7 \text{ V}$	-	0.7	
		$I_{OL} = 30 \text{ mA}, V_{CC} = 1.8 \text{ V}$	-	0.6	
		$I_{OL} = 80 \text{ mA}, V_{CC} \geq 2.7 \text{ V}$	-	0.7	
V_{OH}	COM IO output high level	$I_{OH} = 8 \text{ mA}, V_{CC} \geq 2.7 \text{ V}$	$V_{CC}-0.4$	-	V
		$I_{OH} = 4 \text{ mA}, V_{CC} = 1.8 \text{ V}$	$V_{CC}-0.5$	-	

- IO types can refer to the terms and symbols defined by the pins.
- COM_L IO current 80mA/60mA/40mA/20mA can be software set.
- Data is based on assessment results and is not tested in production.

5.3.14. NRST pin characteristics

Table 5-24 NRST pin characteristics

Symbol	Parameter	Condition	Min	Typ	Max	Unit
V_{IH}	Input high level voltage	$V_{CC}=1.7 \sim 5.5 \text{ V}$	$0.7V_{CC}$	-	-	V
V_{IL}	Input low level voltage	$V_{CC}=1.7 \sim 5.5 \text{ V}$	-	-	$0.2V_{CC}$	V
$V_{hys}^{(1)}$	Schmitt hysteresis voltage	-	-	300	-	mV
I_{lkg}	Input leakage current	-	-	-	1	μA
$R_{PU}^{(1)}$	Pull-up resistor	-	30	50	70	$k\Omega$
$R_{PD}^{(1)}$	Pull-down resistor	-	30	50	70	$k\Omega$
C_{IO}	Pin capacitance	-	-	5	-	pF

1. Guaranteed by design, not tested in production.

5.3.15. ADC characteristics

Table 5-25 ADC characteristics

Symbol	Parameter	Condition	Min	Typ	Max	Unit
V_{CC}	Analog supply voltage for ADC ON	-	1.7	-	5.5	V
I_{CC}	Power consumption	@0.75 MSPS	-	1.0	-	mA
$C_{IN}^{(1)}$	Internal sample and hold capacitors	-	-	5	-	pF

Symbol	Parameter	Condition	Min	Typ	Max	Unit
f _{ADC}	Convert clock frequency	V _{CC} =1.7 ~ 2.3 V	1	4	6 ⁽²⁾	MHz
		V _{CC} =2.3 ~ 5.5 V	1	8	12 ⁽²⁾	MHz
t _{samp} ⁽¹⁾	Sampling time	V _{CC} =1.7 ~ 5.5 V	3.5	-	239.5	1/f _{ADC}
t _{samp_setup} ⁽¹⁾	Sampling build-up time for V _{REFINT}	f _{ADC} =12 MHz	15	-	-	μs
t _{conv} ⁽¹⁾	Total conversion time	-	-	12	-	1/f _{ADC}
t _{eoc} ⁽¹⁾	Conversion end time	-	-	0.5	-	1/f _{ADC}
DNL ⁽²⁾	Differential linearity error	-	-	±2	-	LSB
INL ⁽²⁾	Integral linearity error	-	-	±3	-	LSB
Offset ⁽²⁾	Offset error	-	-	±2	-	LSB

1. Guaranteed by design, not tested in production.
2. Data is based on assessment results and is not tested in production.

5.3.16. Comparator characteristics

Table 5-26 Comparator characteristics⁽¹⁾

Symbol	Parameter	Condition	Min	Typ	Max	Unit	
V _{IN}	Input voltage range	-	0	-	V _{CC}	V	
V _{BG}	Scale input voltage	-	V _{REFINT}				
V _{SC}	Scaler offset voltage	-	-	±5	±10	mV	
I _{CC(SCALER)}	Scaler static consumption	-	-	0.8	1	μA	
t _{START_SCALER}	Scaler startup time	-	-	100	200	us	
t _{START}	Startup time to reach propagation delay specification	High-speed mode	-	-	5	us	
		Medium-speed mode	-	-	15		
t _D	Propagation delay	High-speed mode	200 mV step; 100 mV over-drive	-	40	70	ns
			>200 mV step; 100 mV over-drive	-	-	85	us
		Medium-speed mode	200 mV step; 100 mV over-drive	-	0.9	2.3	us
			>200 mV step; 100 mV over-drive	-	-	3.4	ns
V _{offset}	Offset error	-	-	±5	-	mV	
V _{hys}	Hysteresis	No hysteresis	-	0	-	mV	
		With hysteresis	-	20	-		
I _{CC}	Consumption	High-speed mode; No deglitcher	Static	-	250	-	μA
			With 50 kHz and ±100 mv overdrive square signal	-	250	-	
		Medium-speed mode With deglitcher	Static	-	7	-	μA
			With 50 kHz and ±100 mv	-	8	-	

Symbol	Parameter	Condition	Min	Typ	Max	Unit
		overdrive square signal				

1. Guaranteed by design, not tested in production.

5.3.17. Temperature sensor characteristics

Table 5-27 Temperature sensor characteristics

Symbol	Parameter	Min	Typ	Max	Unit
$T_L^{(1)}$	V_{TS} linearity with temperature	-	± 1	± 2	$^{\circ}\text{C}$
Avg_Slope ⁽¹⁾	Average slope	2.3	2.5	2.7	mV/ $^{\circ}\text{C}$
V_{30}	Voltage at 30 $^{\circ}\text{C}$ (± 5 $^{\circ}\text{C}$)	0.742	0.76	0.785	V
$t_{\text{START}}^{(1)}$	Start-up time entering in continuous mode	-	70	120	us
$t_{\text{S_temp}}^{(1)}$	ADC sampling time when reading the temperature	15	-	-	us

1. Guaranteed by design, not tested in production.
2. Data is based on assessment results and is not tested in production.

5.3.18. Built-in reference voltage characteristics

Table 5-28 Built-in reference voltage characteristics

Symbol	Parameter	Min	Typ	Max	Unit
V_{REFINT}	Internal reference voltage	1.17	1.2	1.23	V
$t_{\text{start_vrefint}}$	Start time of internal reference voltage	-	10	15	us
T_{coeff}	Temperature coefficient	-	-	100 ⁽¹⁾	ppm/ $^{\circ}\text{C}$
I_{VCC}	Current consumption from V_{CC}	-	12	20	uA

1. Guaranteed by design, not tested in production.

5.3.19. Timer characteristics

Table 5-29 Timer characteristics

Symbol	Parameter	Condition	Min	Max	Unit
$t_{\text{res(TIM)}}$	Timer resolution time	-	1	-	t_{TIMxCLK}
		$f_{\text{TIMxCLK}} = 48$ MHz	20.833	-	ns
f_{EXT}	Timer external clock frequency on CH1 to CH4	-	-	$f_{\text{TIMxCLK}}/2$	MHz
		$f_{\text{TIMxCLK}} = 48$ MHz	-	24	
Res_{TIM}	Timer resolution	TIM1/3/14/16/17	-	16	Bit
t_{COUNTER}	16-bit counter clock period	-	1	65536	t_{TIMxCLK}
		$f_{\text{TIMxCLK}} = 48$ MHz	0.020833	1365	us

Table 5-30 LPTIM characteristics (clock selection LSI)

Prescaler	PRESC[2:0]	Minimum overflow	Maximum overflow	Unit
/1	0	0.0305	1998.848	ms
/2	1	0.0610	3997.696	
/4	2	0.1221	8001.9456	
/8	3	0.2441	15997.3376	

/16	4	0.4883	32001.2288	
/32	5	0.9766	64002.4576	
/64	6	1.9531	127998.3616	
/128	7	3.9063	256003.2768	

Table 5-31 IWDG characteristics (clock selection LSI)

Prescaler	PR[2:0]	Minimum overflow	Maximum overflow	Unit
/4	0	0.122	499.712	ms
/8	1	0.244	999.424	
/16	2	0.488	1998.848	
/32	3	0.976	3997.696	
/64	4	1.952	7995.392	
/128	5	3.904	15990.784	
/256	6 or 7	7.808	31981.568	

Table 5-32 WWDG characteristics (clock select 48 MHz PCLK)

Prescaler	WDGTB[1:0]	Minimum overflow	Maximum overflow	Unit
1*4096	0	0.085	5.461	ms
2*4096	1	0.171	10.923	
4*4096	2	0.341	21.845	
8*4096	3	0.683	43.691	

5.3.20. Communication port characteristics

5.3.20.1. I²C bus interface features

I²C interface meets the requirements of the I²C -bus specification and user manual :

- Standard-mode(Sm): 100 kbit/s
- Fast-mode(Fm): 400 kbit/s

Table 5-33 I²C filter characteristics

Symbol	Parameter	Min	Max	Unit
t _{AF}	Limiting duration of spikes suppressed by the filter (Spikes shorter than the limiting duration are suppressed)	50	260	ns

5.3.20.2. Serial Peripheral Interface SPI Characteristics

Table 5-34 SPI characteristics

Symbol	Parameter	Condition	Min	Max	Unit
f _{SCK}	SPI clock frequency	Master mode	-	12	MHz
1/t _{c(SCK)}		Slave mode	-	12	
t _{r(SCK)} t _{f(SCK)}	SPI clock rise and fall time	Capacitive load: C=15 pF	-	6	ns
t _{su(NSS)}	NSS setup time	Slave mode	4 t _{pclk}	-	ns
t _{h(NSS)}	NSS hold time	Slave mode	2 t _{pclk} + 10	-	ns
t _{w(SCKH)} t _{w(SCKL)}	SCK high and low time	Master mode, presc = 4	t _{pclk} * 2 - 2	t _{pclk} * 2 + 1	ns

Symbol	Parameter	Condition	Min	Max	Unit
$t_{su(MI)}$ $t_{su(SI)}$	Data input setup time	Master mode, presc = 4	$t_{pclk} + 5^{(1)}$	-	ns
		Slave mode, presc = 4	5	-	
$t_{h(MI)}$ $t_{h(SI)}$	Data input hold time	Master mode	5	-	ns
		Slave mode	$t_{pclk} + 5$	-	
$t_{a(SO)}$	Data output access time	Slave mode, presc = 4	0	$3 t_{pclk}$	ns
$t_{dis(SO)}$	Data output disable time	Slave mode	$2 t_{pclk} + 5$	$4 t_{pclk} + 5$	ns
$t_{v(SO)}$	Data output valid time	Slave mode (after enable edge), presc = 4	0	$1.5 t_{pclk}^{(2)}$	ns
$t_{v(MO)}$	Data output valid time	Master mode (after enable edge)	-	6	ns
$t_{h(SO)}$ $t_{h(MO)}$	Data output hold time	Slave mode, presc = 4	$0^{(3)}$	-	ns
		Master mode	2	-	
DuCy(SCK)	SPI slave input clock duty cycle	Slave mode	45	55	%

1. The Master generates 1 pclk to receive control signal before the receive edge.
2. Slave has a maximum of 1 PCLK based on the sending edge of SCK delay, considering IO delay, etc., define 1.5 PCLK.
3. In the case that the SCK duty cycle sent by the Master is wide between the receiving edge and the sending edge, the Slave updates the data before the sending edge.

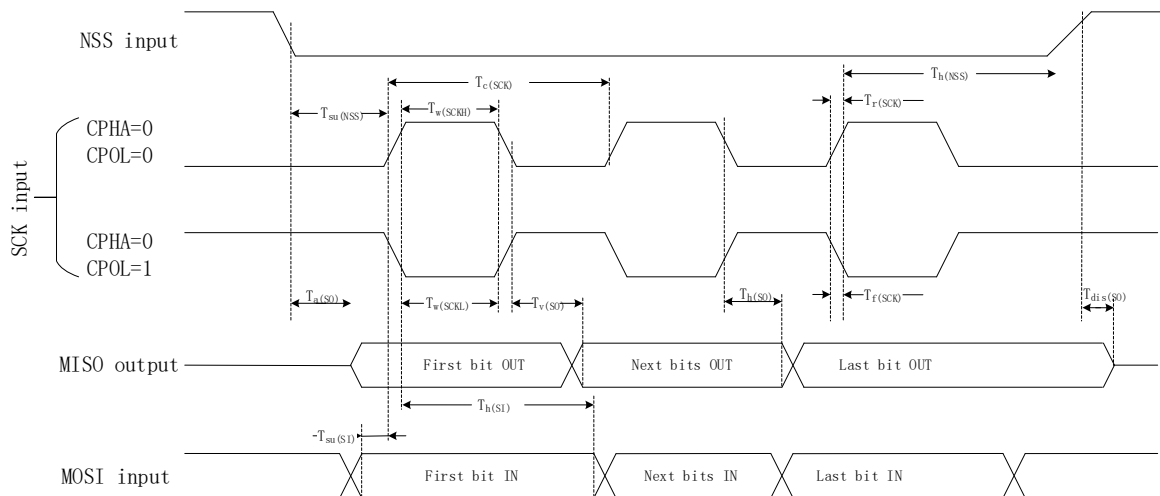

Figure 5-3 SPI timing diagram – Slave mode and CPHA=0

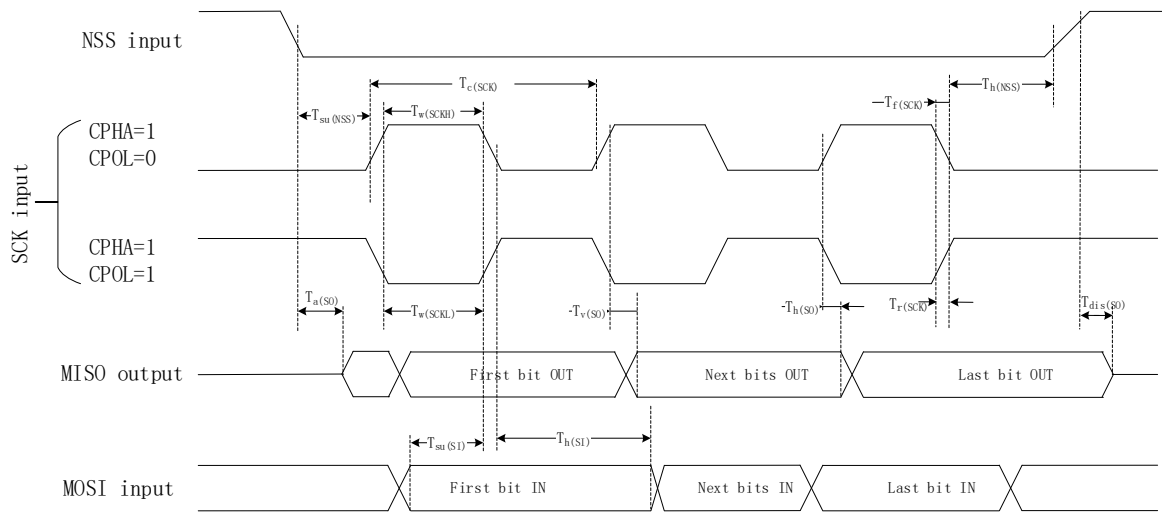

Figure 5-4 SPI timing diagram – Slave mode and CPHA=1

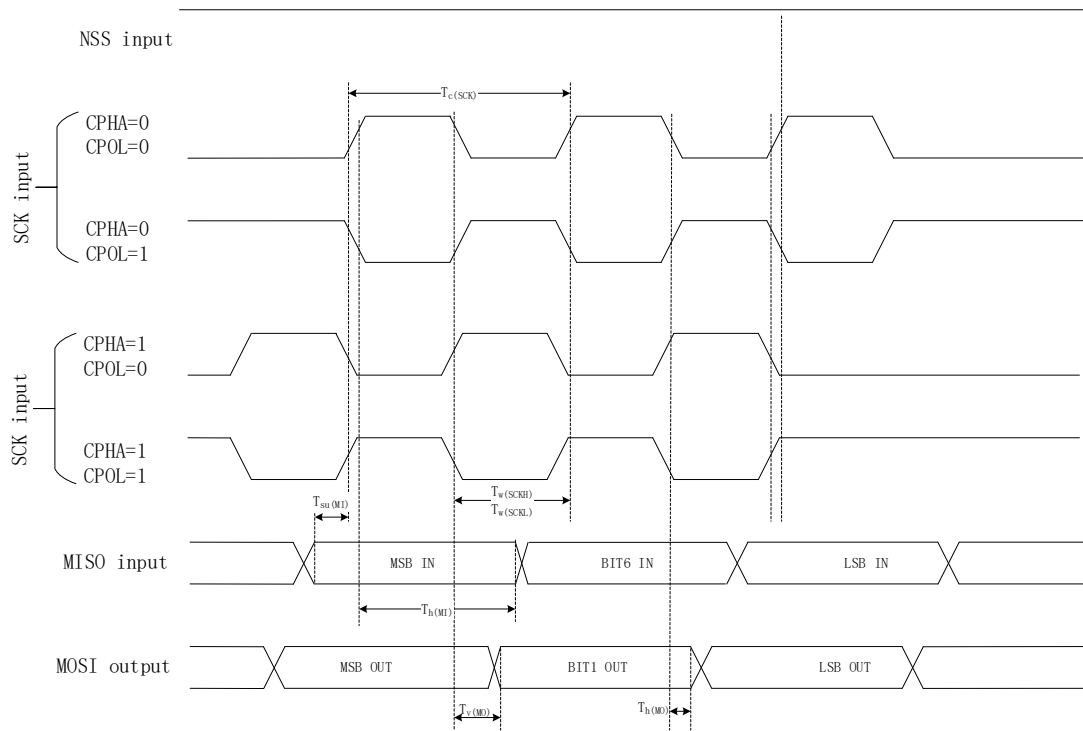

Figure 5-5 SPI timing diagram – Master mode

6. Package Information

6.1. LQFP32

Note 2:

Common Dimensions
(Unit of Measure=millimeters)

Symbol	Min	Typ	Max
A	-	-	1.600
A1	0.050	-	0.150
A2	1.350	1.400	1.450
b	0.300	-	0.450
c	0.100	-	0.200
D	8.800	9.000	9.200
D1	6.800	7.000	7.200
E	8.800	9.000	9.200
E1	6.800	7.000	7.200
e		0.800BSC	
L	0.450	-	0.750
L1		1.000REF	
θ	0	-	7°

Note: 1. Dimensions are not to scale
2. Have two shape can be compatible with each other

	TITLE Puya LQFP32L 7x7X1.4-0.8PITCH	DRAWING NO. QRPD-0040	REV 1.0
--	--	--------------------------	------------

6.2. QFN32(5*5)

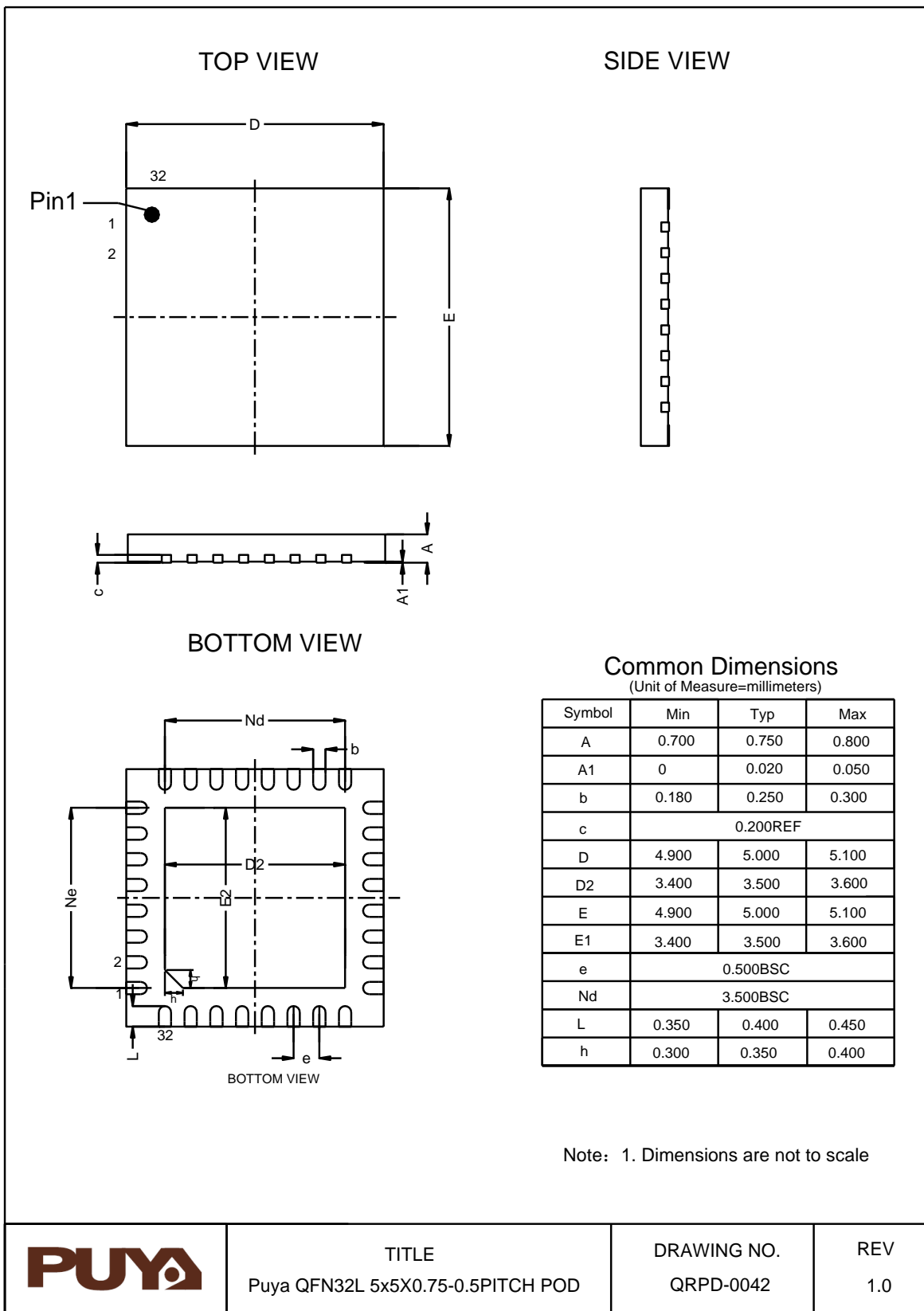

6.3. QFN32(4*4)

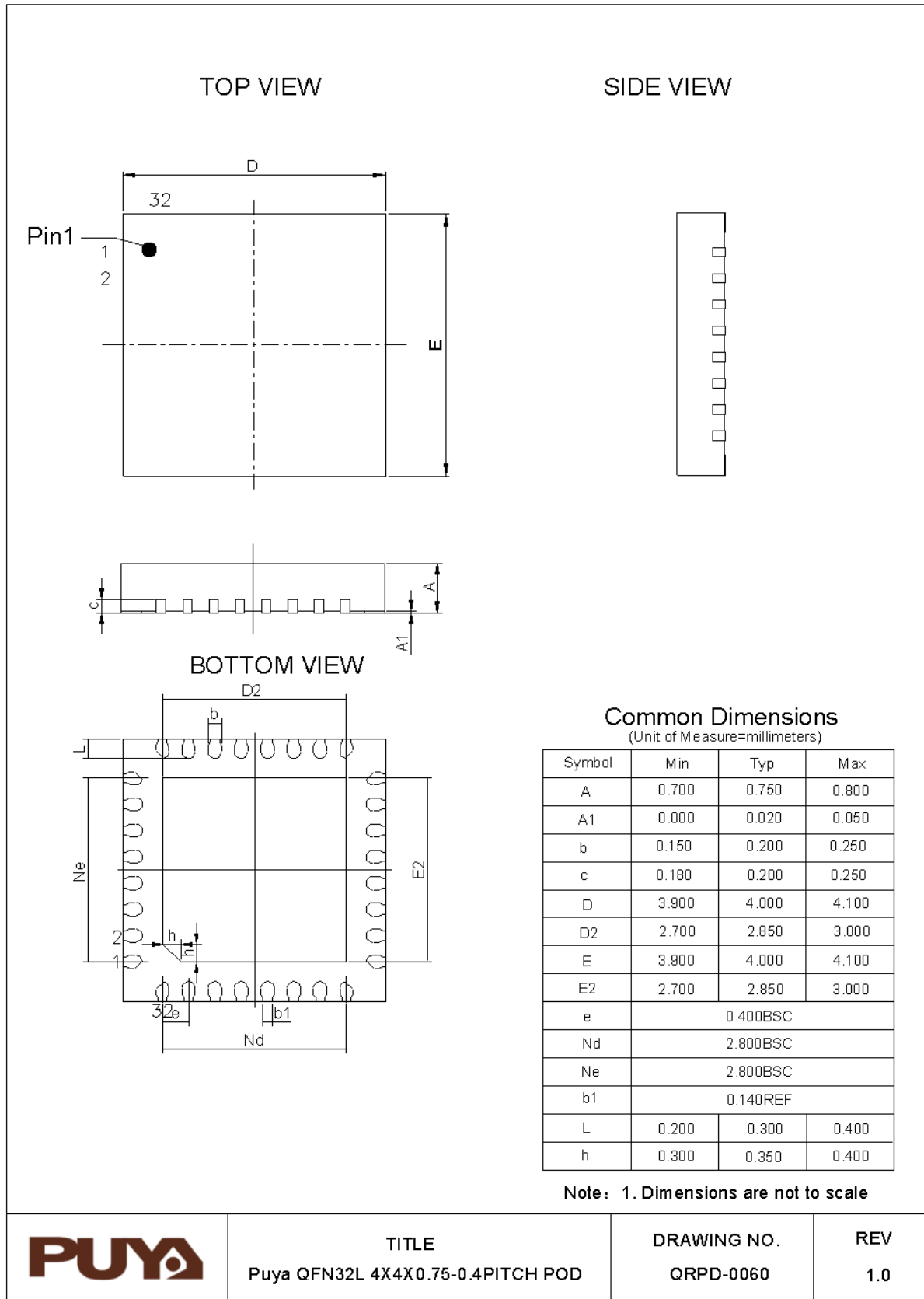

6.4. QFN24

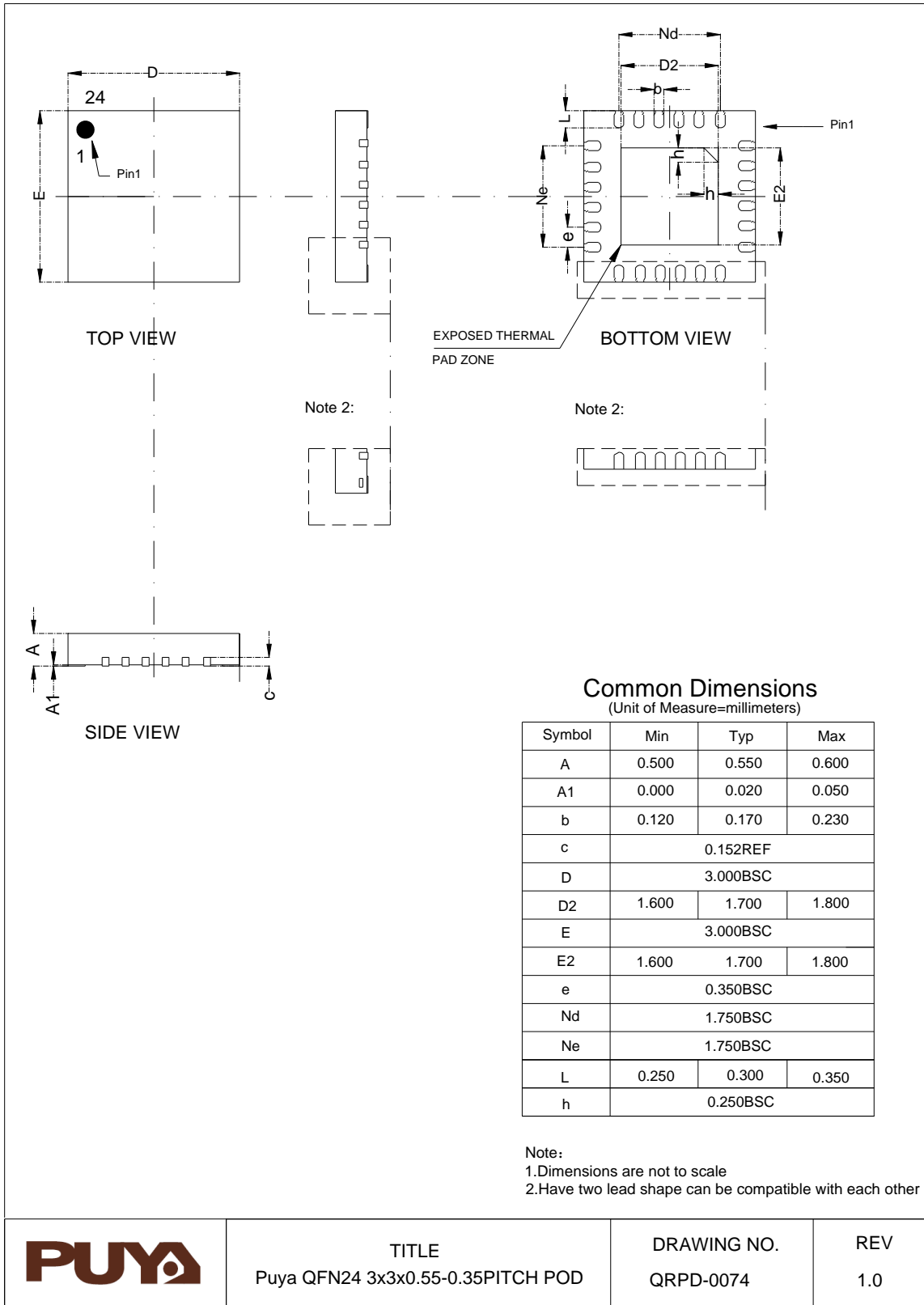

6.5. SSOP24

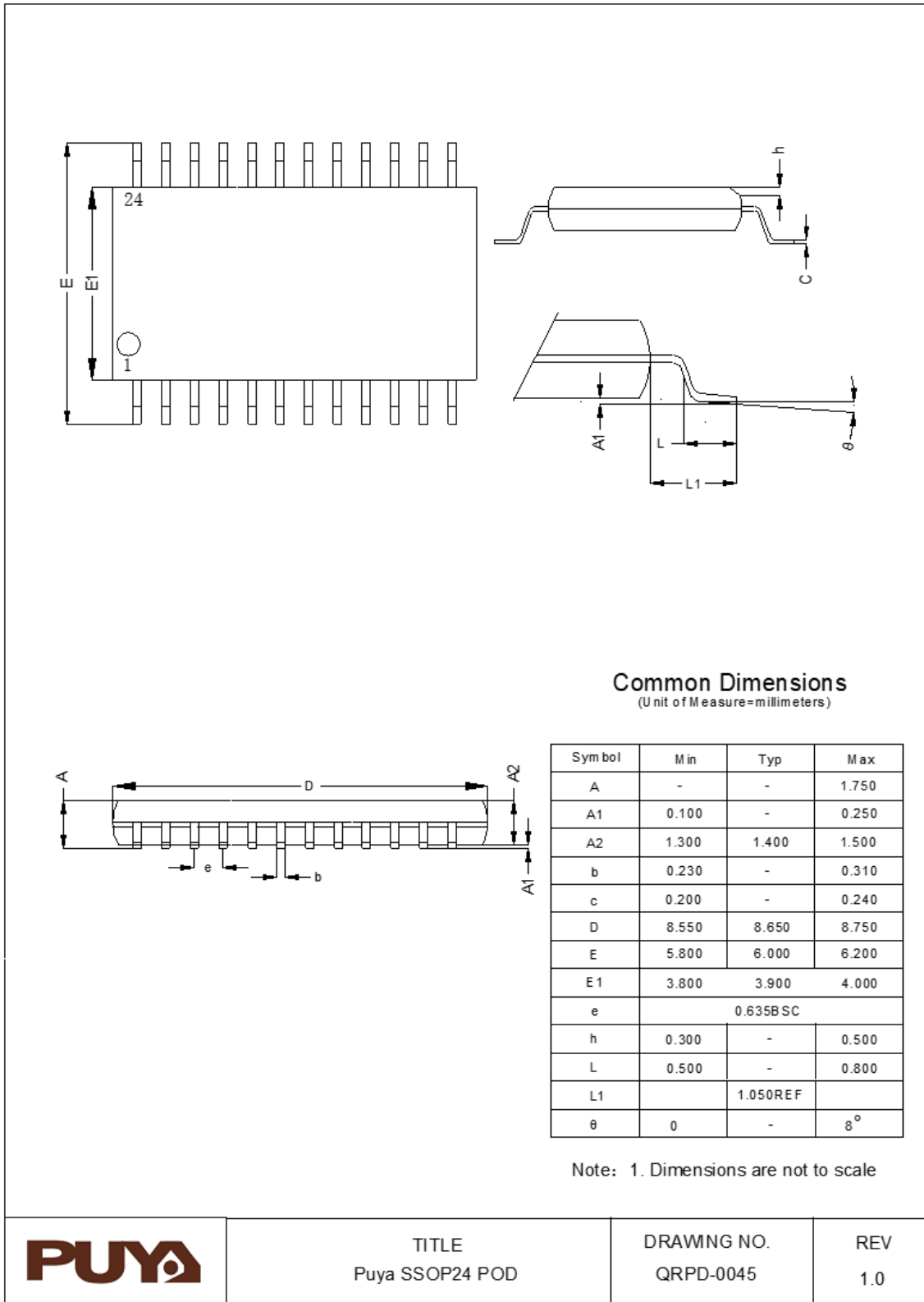

6.6. QFN20

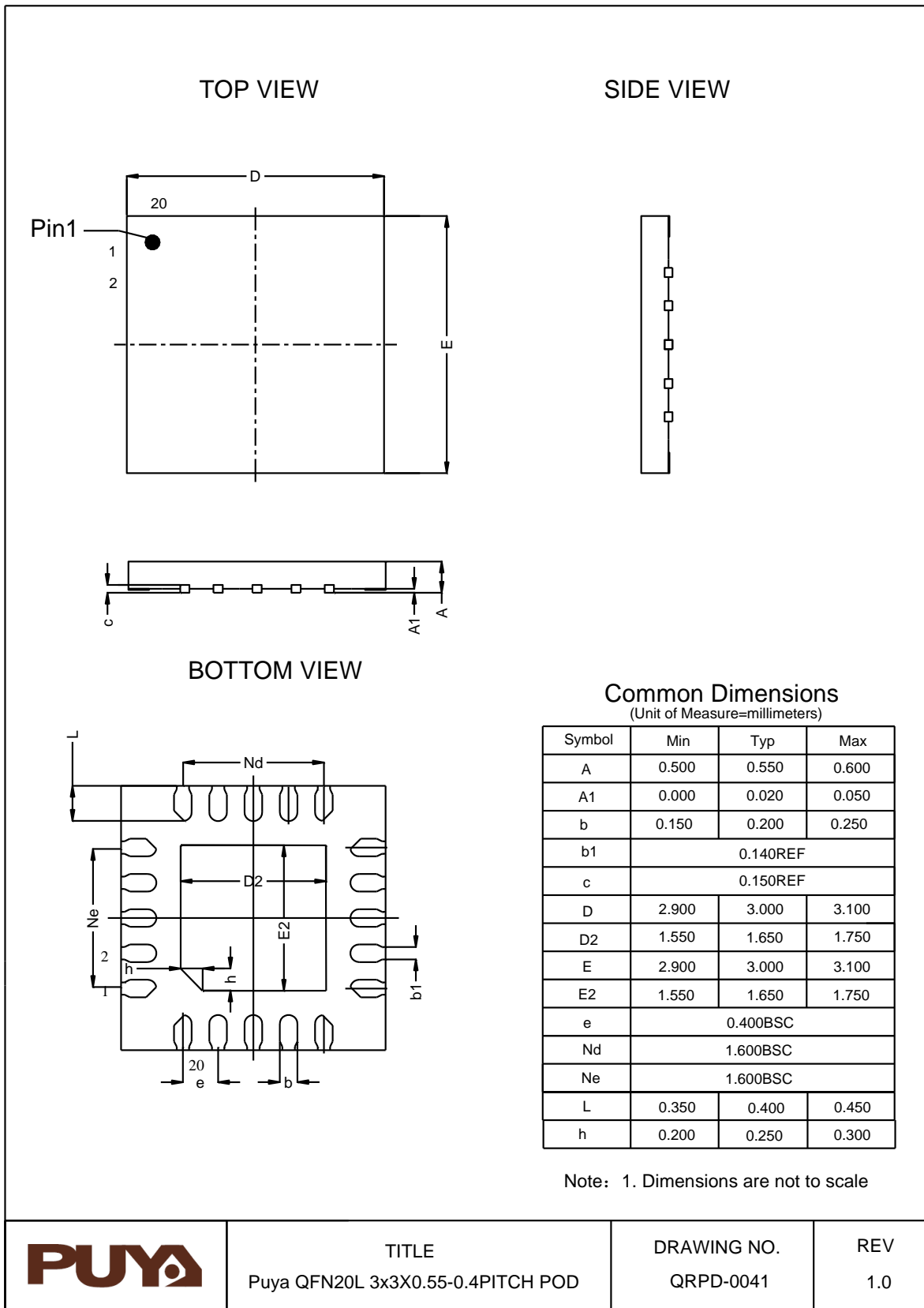

6.7. TSSOP20

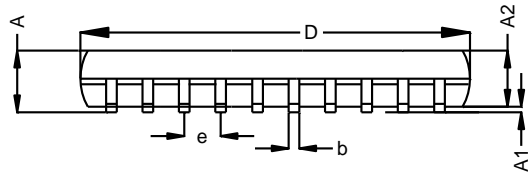
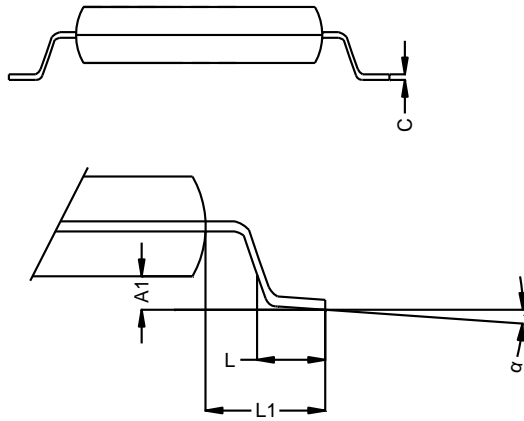
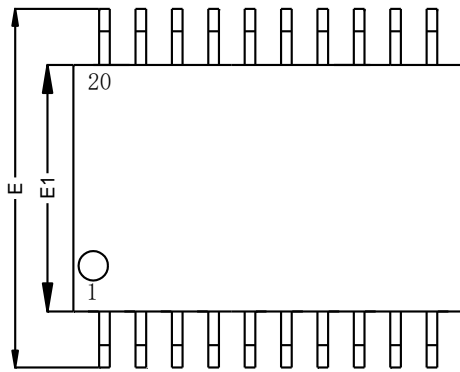

Common Dimensions
(Unit of Measure=millimeters)

Symbol	Min	Typ	Max
A	-	-	1.200
A1	0.050	-	0.150
A2	0.800	1.000	1.050
b	0.200	-	0.280
c	0.090	-	0.200
D	6.400	6.500	6.600
E	6.200	6.400	6.600
E1	4.300	4.400	4.500
e	0.650BSC		
L	0.450	0.600	0.750
L1	1.000REF		
θ	0	-	8°

Note: 1. Dimensions are not to scale



TITLE
Puya TSSOP20 POD

DRAWING NO.
QRPD-0043

REV
1.0

6.8. DFN8(1.5*1.5)

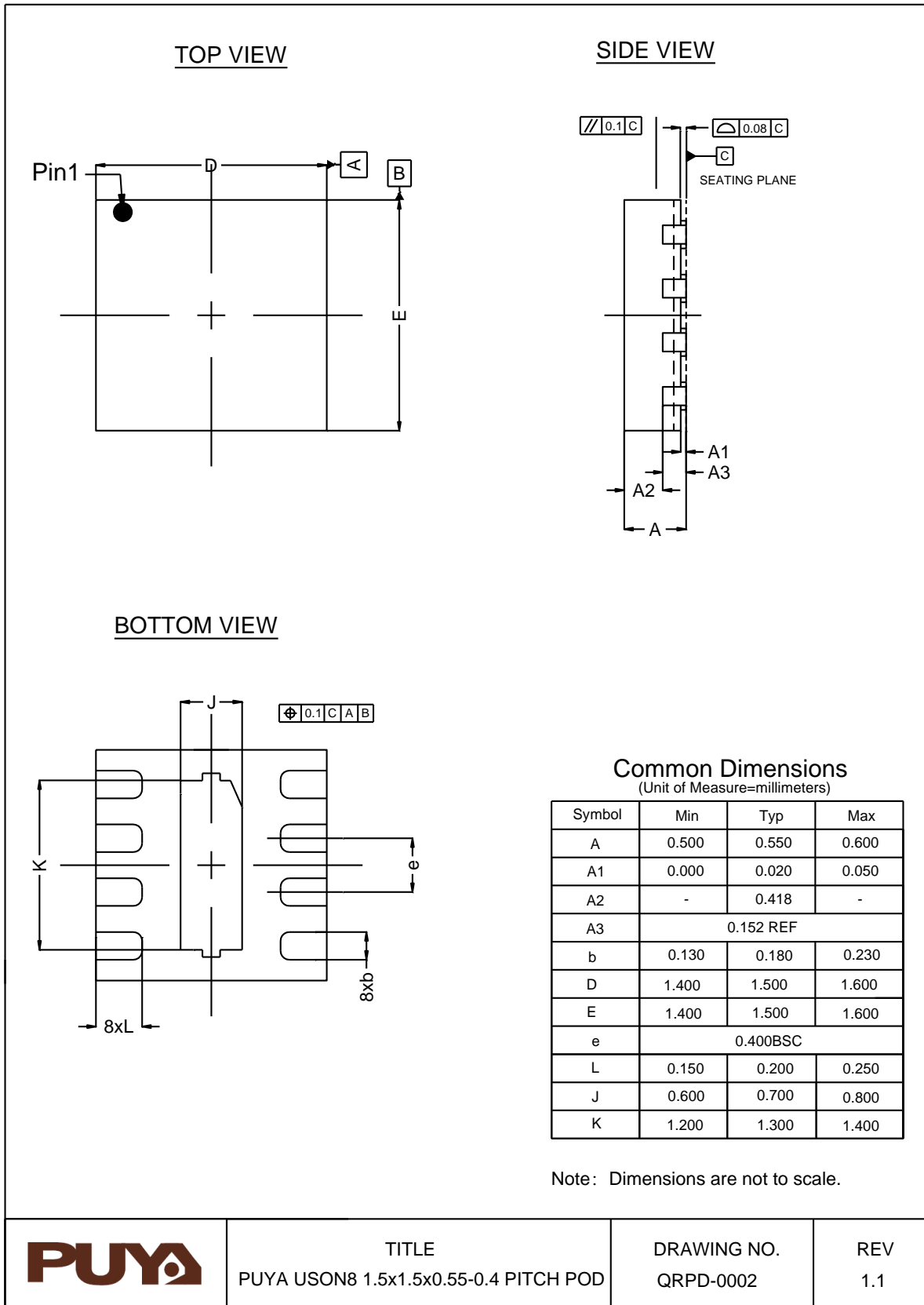

7. Ordering Information

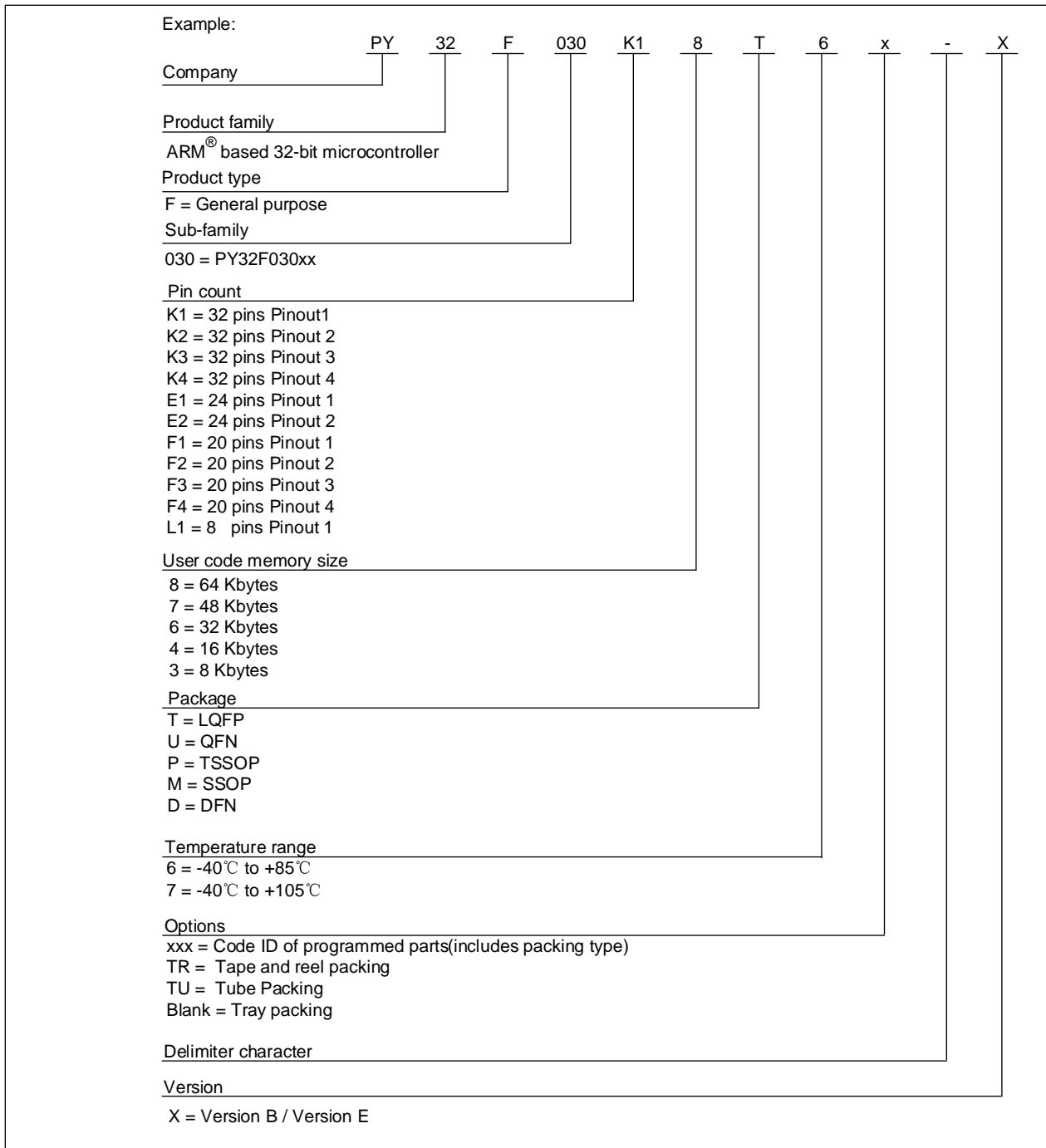

8. Version History

Version	Date	Updated the record
V1.0	2022.10.20	Initial version
V1.1	2021.12.09	<ol style="list-style-type: none"> Delete SSOP24 package information Add "TU= Tube Packing" to ordering information Section 6.3.9, modifying parameters
V1.2	2021.12.28	<ol style="list-style-type: none"> Modify the format Section 6.3.4 , modifying parameters Section 6.3.16, modifying parameters Chapter 4, LQFP32 Pinout1 pin configuration modification
V1.3	2022.1.13	<ol style="list-style-type: none"> Added chapter 6.3.11 Modify chapter 3.15, modify parameters Add TSSOP20/QFN20 Pinout2 package
V1.4	2022.1.24	<ol style="list-style-type: none"> Table 6-18, modify parameters Table 6-33, modify parameters Chapter 8, modifying parameters
V1.5	2023.3.09	<ol style="list-style-type: none"> Add SSOP24 package
V1.6	2023.1.18	<ol style="list-style-type: none"> Add QFN24/ QFN32(4*4)/ DFN8 packages
V1.7	2024.2.5	<ol style="list-style-type: none"> Add QFN32 product: PY32F030K46U6TR-E
V1.8	2024.6.07	<ol style="list-style-type: none"> Merge PY32F030x6 and PY32F030x7 versions Add QFN24 Pinout1 - E / SSOP24 Pinout2 - E product Table 5-19 / 5-20, modify parameters
V1.9	2024.7.30	<ol style="list-style-type: none"> Add TSSOP20 Pinout2 – E
V2.0	2024.9.12	<ol style="list-style-type: none"> Add QFN20 Pinout1 – E
V2.1	2024.9.25	<ol style="list-style-type: none"> Add QFN32(4*4) product: PY32F030K48U7-E
V2.2	2024.10.09	<ol style="list-style-type: none"> Add QFN32(5*5) product: PY32F030K28U7-E
V2.3	2024.12.24	<ol style="list-style-type: none"> Add QFN20 product: PY32F030F28U7-E
V2.4	2025.03.20	<ol style="list-style-type: none"> Add DFN8 product PY32F030L18D6-E
V2.5	2026.5.22	<ol style="list-style-type: none"> Delete LQFP32 product: PY32F030K17T6、PY32F030K16T6、PY32F030K27T6、PY32F030K24T6、PY32F030K18T7、PY32F030K17T7、PY32F030K14T7、PY32F030K27T7、PY32F030K26T7、PY32F030K24T7 Delete QFN20 product: PY32F030F17U6、PY32F030F27U6、PY32F030F18U7、PY32F030F17U7、PY32F030F16U7、PY32F030F27U7、PY32F030F26U7 Delete DFN8 (1.5*1.5) product: PY32F030L16D6 Delete SSOP24 product: PY32F030E18M7 Delete TSSOP20 product: PY32F030F18P7、PY32F030F17P7、PY32F030F28P7



Puya Semiconductor Co., Ltd.

IMPORTANT NOTICE

Puya reserve the right to make changes, corrections, enhancements, modifications to Puya products and/or to this document at any time without notice. Purchasers should obtain the latest relevant information of Puya products before placing orders.

Puya products are sold pursuant to terms and conditions of sale in place at the time of order acknowledgement.

Purchasers are solely responsible for the choice and use of Puya products. Puya does not provide service support and assumes no responsibility when products that are used on its own or designated third party products.

Puya hereby disclaims any license to any intellectual property rights, express or implied.

Resale of Puya products with provisions inconsistent with the information set forth herein shall void any warranty granted by Puya.

Any with Puya or Puya logo are trademarks of Puya. All other product or service names are the property of their respective owners.

The information in this document supersedes and replaces the information in the previous version.

Puya Semiconductor Co., Ltd. – All rights reserved